



*CountrySide Proprietary
Community Guidelines Handbook*

EFFECTIVE January 1, 2025
COUNTRYSIDE PROPRIETARY
21515 Ridgetop Cir. Suite 280, Sterling VA, 20166

Table of Contents

- Community Guidelines Handbook* 0
- Overview 1
 - Introduction..... 1
 - What do you need to know? 1
 - The Design Review process 2
 - Application contents 3
 - Design Review criteria 3
 - Definitions 5
 - Amendments to the Guidelines 6
- Exterior Alterations Requiring Applications..... 7
 - 1. Air conditioners and heat pumps (single family, townhouse, and manor home)..... 7
 - 2. Attic ventilators (single family, townhouse, and manor home) 7
 - 3. Awnings (single family) 7
 - 4. Awnings (townhouse and manor home) 7
 - 5. Barbecues, permanent (single family and manor home) 8
 - 6. Barbecues, permanent (Townhouse)8
 - 7. Addition of a basement emergency exit (non-walk out basement) (Single family, manor, TH).....8
 - 8. Chimneys and metal flues (Single Family, townhouse, and manor home)9
 - 9. Color Changes (Single Family)9
 - 10. Color Changes (Townhouse)10
 - 11. Color Changes (Manor Homes)10
 - 12. Compost Bins (Single Family and Manor Homes)10
 - 13. Decks (Single Family and Manor Homes)13
 - 14. Decks (Townhouse)15
 - 15. Decorative Objects (Single Family, Townhouse and Manor Home)16
 - 16. Dog Houses and Dog Runs (Single Family, Townhouse and Manor Homes)16
 - 17. Doors (Single Family, Townhouse and Manor Homes)16
 - 18. Driveways and driveway extensions19
 - 19. Entrance Walks (Single Family and Manor Homes)19
 - 20. Entrance Walks (Townhouse)20
 - 21. EV, Electric Vehicle Charging Stations, or Boxes (Single Family, Townhouse and Manor Home)21

22. Fences (single family, townhouse, and manor homes).....	21
23. Firewood (single family, townhouse, and manor home)	25
24. Garage renovation.....	25
25. Garden trellises and arbors (single family, townhouse, and manor house)	26
26. Gazebos (single family).....	27
27. Gazebos (townhouse).....	27
28. Generators (single family, townhouse and Manor home).....	28
29. Greenhouses (single family, townhouse, and manor home)	28
30. Gutters and downspouts (single family, townhouse, and manor home)	29
31. Hot tubs and spas (single family, townhouse, and manor home)	29
32. Landscaping (single family, townhouse, and manor home)	29
33. Lighting (single family, townhouse, and manor homes)	31
34. Open Porches (single family)	34
35. Open Porches (townhouse and manor home).....	34
36. Patios and ground level decks (single family, townhouse, and manor home)	35
37. Play equipment (single family, townhouse, and manor home)	36
38. Propane tanks (single family, townhouse, and manor home)	37
39. Radon remediators (single family, townhouse, and manor home)	38
40. Railings and ramps (single family, townhouse, and manor home).....	38
41. Rain barrels (single family, manor homes and townhomes)	38
42. Roof shingles (single family and manor home)	39
43. Roof shingles (townhouse)	40
44. Room additions/house expansion (single family)	42
45. Room additions/house expansion (townhouse)	44
46. Room additions/house expansion (manor homes).....	45
47. Screened porches (single family)	45
48. Screened porches (townhouse and manor home).....	46
49. Sheds (single family)	46
50. Sheds (townhouse)	47
51. Sheds (manor home)	48
52. Shutters (single family, townhouse, and manor home).....	49
53. Siding (single family, townhouse, and manor home).....	49
54. Skylights (single family, townhouse, and manor home)	52
55. Solar panels (single family, townhouse, and manor homes)	52

56. Swimming pools.....	53
57. Temporary storage containers (pods, dumpsters, rolls offs) single family and manor home	53
58. Temporary storage containers (pods, dumpsters, rolls offs) townhouse	53
59. Tree removal (single family, townhouse, and manor home)	54
60. Trim & trim wrap (all neighborhoods).....	54
61. Water features, and ponds (single family, townhouse, and manor).....	56
62. Windows (single family, townhouse, and manor home).....	56
Exterior Alterations NOT Requiring Applications	58
Chimney caps (single family, townhouse, and manor home)	58
Electronic insect traps (single family, townhouse, and manor home).....	58
Flagpoles (single family, townhouse, and manor home).....	58
Mailboxes (single family and manor home)	58
Play equipment, temporary (single family, townhouse, and manor home)	59
Satellite dishes and antennas (single family, townhouse, and manor home).....	59
Signs (single family, townhouse, and manor home)	60
Sprinklers (single family, townhouse, and manor home).....	60
Vegetable gardens (single family, townhouse, and manor home).....	60
Other (single family, townhouse, and manor home)	60
Prohibitions	61
Maintenance guidelines	62
During construction	62
Erosion control	62
Exterior appearance	62
Firewood.....	62
Lawns.....	63
Mailboxes.....	63
Pesticides, herbicides, and fertilizers	63
Trash containers	63
Trash removal	63
Construction requirements	64
County permits	64
Quality of work	64
Vehicle parking	65
Appendix A. – Standards and Neighborhood Guidelines	66

CountrySide Boulevard Approved Fence Standard.....	67
Townhouse Approved Standard Fence.....	68
Requirements for Standard Townhouse Decks and Patios	70
Townhouse Patio Door Standards	71
Globe <i>Colonial</i> Townhomes Foxfield	71
Globe <i>Colonial</i> Townhomes Oakridge and Welbourne	71
Oakridge and Morven <i>Tudor</i> Townhouses Patio Door Standards	71
Morven and Welbourne <i>Scarborough</i> Townhouses.....	72
Foxfield Townhouses Entry Door Standards.....	73
Foxfield Townhouses <i>Rear</i> Entry Door Standard	75
Morven Tudor Townhouse Entry Door Standards.....	76
Morven Tudor Townhouse Entry Door Standards Cont'd	77
Morven Scarborough Townhouses Entry Door Standards	77
Oakridge Globe Townhouses Entry Door Standards	78
Oakridge Tudor Townhouses Entry Door Standards	79
Welbourne Townhouse Entry Door Standards.....	80
Welbourne Townhouse <i>Rear</i> Entry Door Standard	81
Belmont - Neighborhood III- Storm Door Standards	82
Foxfield Standard Storm Doors.....	83
Morven Single Family Homes Storm Door Standards.....	84
Morven Tudor Townhouses Storm Door Standards	85
Morven Scarborough Townhouses Storm Door Standards	86
Oakridge Single Family Homes Storm Door Standards.....	87
Oakridge Globe Colonial Townhouses Storm Door Standards	88
Oakridge Tudor Townhouses Storm Door Standards	89
Oatlands Storm Door Standards	90
Rokeby Ridge Single Family Homes Storm Doors Standards	91
Welbourne Standard Storm Doors (Globe townhouses).....	92
Welbourne Standard Storm Doors (Scarborough townhouses).....	93
Standard for Garage Door Material Change All Neighborhoods with Garages	94
Standard for Walkways.....	95
Standard for Material Change (Trim) (All Neighborhoods)	96
Exterior Lighting - Wattage Guidelines	97
Oatlands Standard Mailbox Post Color	98

Oatlands Standard Basketball Equipment.....	98
Appendix B – Application Checklists.....	99
Color Change Checklist.....	100
Color Change Application Grid.....	101
Deck/Patio Application Checklist.....	102
Enclosed Structure Application Checklist.....	104
Fence Application Checklist.....	105
Lighting Application Checklist.....	107
Shed Application Checklist.....	108
Window Check List.....	109
Standard Townhouse Deck/Patio Application Checklist.....	110
Standard Townhouse Fence Checklist.....	112
Standard Townhouse Roof Checklist.....	113
Standard Walkway Checklist.....	114
Appendix C- Contents and Samples.....	115
Definitions.....	116
Sample 1 – Standard Storm Door.....	117
Sample 2- Standard Townhouse Deck.....	118
Standard Townhouse Deck/Patio Application Checklist.....	119
Sample Property/Site Plat.....	120
Sample 3 - Attic Ventilator.....	121
Sample 4- Fence.....	121
Appendix D – Illustrations.....	124
Standard Townhouse Deck.....	125
Fence Styles (single family and manor homes).....	126
Spaced Picket (single family and manor home).....	128
Estate and Split Rail Fence (single family and manor home).....	129
Flat cap picket Fence style (Oatlands).....	130
Standard Townhouse Fence.....	132
Roof Slope Comparison.....	135

Overview

Introduction

CountrySide is a special place to live because homeowners take pride in the appearance of their community. Much of the beauty of CountrySide lies in its large open spaces. The finishing touch is added by well-designed harmonious architecture and well-maintained lots and homes. The CountrySide Proprietary, our homeowner's association, is charged with preserving the value and use of open space and ensuring the retention of harmonious, though diverse, design qualities in the community.

The quality of design and architectural harmony in CountrySide are maintained through a process of review for all exterior alterations to the property. Specific authority for maintaining the quality of design in CountrySide is established by the Covenants and Restrictions, which are a part of every deed to property. Article VI, Section 1 of the Covenants states,

... except for purposes of maintenance and repair, no building, fence, wall or other improvements or structures shall be commenced, directed, placed, moved, altered or maintained upon The Property, nor shall any exterior addition to or change (including any change of color) or other alteration thereupon be made until the complete plans and specifications showing the location, nature, shape, height, material, color, type of construction and any other proposed form of change (including, without limitation any other information specified by the Design Review Committee) shall have been submitted to and approved in writing as to safety, harmony of external design, color and location in relation to surrounding structures and topography and conformity with the design concept for the community by a Design Review Committee designated by the Board of Directors.

The Design Review Committee (DRC) is made up of seven members, each representing one of the seven neighborhoods of CountrySide. DRC members are appointed by the Proprietary and Board of Directors for one-year terms.

What do you need to know?

It would be worthwhile for all CountrySide homeowners to be thoroughly familiar with the foundation and rationale for the design review process as well as the process itself. However, if you only want to know what you must do to apply for a change to your property, read the second and third paragraphs under **THE DESIGN REVIEW PROCESS** and **APPLICATION CONTENTS**, below. You should also read the specific guideline pertaining to the alteration you are proposing. Appendix C contains simple applications and an explanation of the application requirements.

The Design Review process

This Handbook is divided into two major sections. *Exterior Alterations Requiring Applications* and *Exterior Alterations Not Requiring Applications*. For all alterations listed under *Exterior Alterations Not Requiring Applications*, simple compliance with all stated guidelines shall constitute approval. For all other alterations, whether specific guidelines are listed or not, an application is required. Appendix A contains Standards, for which there is an abbreviated application process.

You may obtain a Design Review Application from the Proprietary office. Completed applications are due at the Proprietary Office on the first of the month to be reviewed that month. In order to be considered, your application must be complete and include all information specified on the application form (including signatures of your four most affected neighbors¹), any checklist, and the relevant guideline subsection of this Handbook. If you are applying for a Standard, see Appendix A.

After the DRC Coordinator has checked your application for completeness, it is sent to your Neighborhood Advisory Council (NAC) for preliminary review. Your presence at the NAC meeting may help if any clarification of your application is required. The NAC reviews the application and makes site visits, with special emphasis on how the proposed alteration would fit in with the architecture and environment of your neighborhood as well as any special concerns neighbors may have. The NAC records its ruling and forwards the application for DRC review. Homeowners who are aggrieved by the NAC ruling may file an appeal to the DRC within ten (10) days after the NAC meeting.

Each DRC member receives a complete set of all applications. DRC members are responsible for thoroughly reviewing each application and, if necessary, viewing the location of the proposed alteration. At their monthly meeting, DRC members will hear any concerns of the NAC or any homeowners. If you are proposing a large or complex alteration, you may find it helpful to attend the meeting at which your application is being considered.

After listening to and questioning any concerned NAC members or homeowners (including yourself), the DRC will discuss the application and vote. In its discussion and vote, the DRC takes into consideration: the requirements of the covenants; the requirements of the specific guidelines and other general guidance provided in this Handbook; the NAC ruling; and the concerns of any homeowners.

If you, as an applicant or as an aggrieved homeowner, are unsatisfied with the DRC's ruling, you may file an appeal to the Board of Directors within ten (10) days after the DRC meeting. The Board will then review an appeal (which may be either written or in person) at its regular meeting the following month or at a specially scheduled architectural meeting shortly thereafter.

After each meeting where your application is considered, you will be notified in writing of the outcome, except in the case of NAC approvals. Any approval is valid **ONLY** if the improvement /modification is done within the boundaries of the applicant's property. **Please do not begin alteration of your property until the final approval has been given** (the eleventh day after the DRC meeting or, if an appeal to the DRC ruling has been filed, after the Board of Directors has approved the application.) If an appeal to the Board of Directors results in denial, that decision is final, and you may not proceed with the alteration.

¹ However, signatures on the application do NOT denote approval by your neighbor, rather awareness that an applicant has applied for an alteration.

Application contents

Each guideline subsection lists the information that must be included in your application for that alteration. An explanation of each type of information and completed sample applications are shown in Appendix C of this Handbook.

Design Review criteria

The DRC evaluates all submissions on the individual merits of the application. Besides examination of the particular design proposal, this includes consideration of the characteristics of the housing type and the individual site since what may be an acceptable design of an exterior in one instance may not be for another. For example, on townhouses, due to their proximity to one another, exterior changes are more noticeable and have more of an impact on adjoining properties than do changes on a detached house.

Design decisions made by the DRC in reviewing applications are based on judgments of acceptable design using the following criteria which represent, in more specific terms, the general standards of the Covenants and Restrictions.

Conformance with Covenants

All applications are reviewed to confirm that the project is in conformance with the Covenants and Restrictions.

Relation to the CountrySide Open Space Concept

Fencing can have damaging effects on open space. Other factors, such as removal of trees, disruption of the natural topography, and changes in rate or direction of storm water runoff also adversely affect Countryside's open space.

Validity of Concept

The basic idea must be sound and appropriate to its surroundings.

Design Compatibility

The proposed alteration shall be compatible with the architectural characteristics of the applicant's house, adjoining houses, and the neighborhood setting. Compatibility is defined as similarity in architectural style, quality of workmanship, similar use of materials, colors, and construction details.

Location and Impact on Neighbors

The proposed alteration shall relate favorably to the landscape, the existing structure, and to the neighborhood. The primary concerns are access, view, sunlight, ventilation, and drainage. For example, fences may obstruct views and breezes. Decks or larger additions may cause unwanted shadows on an adjacent patio or infringe on a neighbor's privacy. When a proposed alteration has possible impact on adjacent properties, it is suggested that the applicant discuss the proposal with neighbors prior to making application to the DRC.

Scale

Scale is the size of any part of the whole in proportion to the whole or in proportion to other, similar parts of the whole. The size (in three dimensions, where applicable) of the proposed alteration shall relate well to the existing structure, adjacent structures, and to the surroundings. For instance, a new window should not be significantly larger than existing windows or take up too large a portion of the side of the house on which it is placed, lest it be out of proportion with those existing elements. Another example would be a large amount of lattice under a tall deck. If not broken up by framing or plantings, a large amount of lattice would overpower the

deck and possibly, the rear facade of the house. Similarly, a large addition to a small house may be inappropriate.

Color

Color may be used to soften or intensify visual impact. Parts of the addition that are like the existing house, such as roofs, trim, and siding shall match in color.

Materials

Continuity is established using the same materials as are used on the house or compatible materials. For instance, where horizontal siding is used on the original house the same shall be used on any addition. However, a deck or screened porch made of unfinished, pressure treated wood is considered compatible with any house.

Definitions

Case-by-Case Basis

Where it is stated that applications for a particular type of alteration will be considered on a case-by-case basis, each application will be considered specifically on its own merits and within its own environment and context, without reference to previous decisions for similar alterations.

Days

Days are defined as calendar days.

Encroachment

Encroachment- A piece of real property which extends from one property over the line of another landowner's property or the common area. The encroachment may be structural, nonstructural or vegetative.

Garage Renovation

The removal of garage doors and replacement with house doors, windows, or exterior walls while the interior of the garage becomes living space. This does not include the moving of exterior walls to create more interior floor space. When exterior walls are to be moved, the applicable guidelines are **Room Additions/House Expansion**.

Pen

Except as noted under **FENCES**, Location of any fenced area that, at a minimum, does not come within one inch of the rear property line **and** within one inch of the rear side property line on one side for a large lot shall be considered a pen.

Except as noted under **FENCES**, Location of any fenced area that at a minimum, does not come within one inch of the rear property line **and** within one inch of both rear side property lines for a small lot shall be considered a pen.

Shall, Must, Should

Throughout the Guidelines, these verbs have been used purposefully. The use of "shall" within a guideline or part of a guideline indicates that such guideline or part thereof is firm. Only in rare and compelling circumstances will an alteration that does not meet a "shall" guideline be approved. The use of "must" within a guideline or part thereof indicates a somewhat less firm stance. Although the use of "must" shows a strong preference for the guideline as stated, requested deviations may be approved if the alteration is deemed not to be detrimental to the neighborhood. Because of the fuzzy nature of "must" guidelines, there are very few of them. Finally, "should" guidelines suggest a preferred appearance, but reasonable alternatives will be readily approved.

Style

Refers to the general architectural style, such as Tudor, colonial, Victorian, contemporary, etc. not the builder's model name.

Trim

Wooden, usually decorative, elements of a house that are painted. Does not include frame that holds a window, storm door, or screen door together before it is installed.

Amendments to the Guidelines

These Guidelines may be amended. The community will conduct a yearly evaluation of the Guidelines. The actual amendment proceedings will involve public discussions and review by the NAC's, the DRC, and the Board of Directors.

Exterior Alterations Requiring Applications

1. Air conditioners and heat pumps (single family, townhouse, and manor home)

The relocation and addition of units shall consider the visual and air discharge effects (e.g., noise) on neighboring properties. Units shall be located in rear or side yards only. Wall units painted to match siding are permitted. **Window units are prohibited.**

Application Contents - site plat (addition), color photo of affected area, dimensions, elevation, and color

2. Attic ventilators (single family, townhouse, and manor home)

Attic ventilators and other mechanical apparatus requiring penetration of the roof shall be as small as functionally possible. If roof mounted, color shall be whatever color is commercially available which is most compatible with roof color (e.g., black for dark gray roofs, aluminum for light gray roofs). They shall be located on the least visible side of the roof and not extend above the roof line. If mounted on a gable end, the apparatus must match the color of the siding or trim of the house. The Design Review Coordinator can consider the application as “standard”. No signatures are required from neighbors for a “standard” application request.

Application Contents - site plat (other), dimensions, elevation, and color

3. Awnings (single family)

Awnings are restricted to the rear of the home, over doors, windows, decks, and patios. Awnings shall be compatible with the architectural design and scale of the home. They shall be made of canvas or a similar heavy-duty fabric, without fringes, and in a solid color or stripe. Color shall be compatible with the existing color scheme of the house. Awnings of neutral colors shall be considered on a case-by-case basis. The preferred type of awning is retractable and self-storing, with a self-contained support system (i.e., no visible supports or poles). The casing or hood for a retractable, self-storing awning shall be unobtrusive and blend with the surface to which it is attached. Stationary, non-retractable awnings that are completely removable may be used. No poles are permitted with window awnings. Poles are permitted for awnings over sliding glass or French doors, deck, and patios. Stationary awnings (including poles) shall be removed between October 1 and April 30.

Application Contents - site plat (other), color photo of affected area, dimensions, elevation, materials, color, and style of house. Specify if retractable or stationary

4. Awnings (townhouse and manor home)

Awnings are restricted to the rear of the home, over doors, windows, decks, and patios. Awnings shall be compatible with the architectural design and scale of the home. They shall be made of canvas or a similar heavy-duty fabric, without fringes, and in a solid color. Awnings of neutral colors shall be considered on a case-by-case basis. Awnings with stripes may be considered on a case-by-case basis only. The predominant color of the color scheme shall match the house siding. **However, awnings with stripes or neutral colors may be considered on a case-by-case basis, as all**

siding colors are not available in awnings. The preferred type of awning is retractable and self-storing, with a self-contained support system (i.e., no visible supports or poles). The casing or hood for a retractable, self-storing awning shall be unobtrusive and blend with the surface to which it is attached. Stationary, non-retractable awnings that are completely removable may be used. No poles are permitted with window awnings. Poles are permitted for awnings over sliding glass or French doors, decks, and patios. Stationary awnings (including poles) shall be removed between October 1 and April 30.

Application Contents - site plat (other), color photo of affected area, dimensions, elevation, materials, color, and style of house. Specify if retractable or stationary.

5. Barbecues, permanent (single family and manor home)

Permanent barbecues should not be a dominant feature on the landscape and should be located so they will blend as much as possible with the natural background. A permanent barbecue shall be placed in the rear yard, no less than 10 feet from all adjacent property lines. Where more space is available, the barbecue shall be placed as far as possible from adjacent property lines. Maximum height is 5 feet. Supplemental plantings shall be provided to soften the visual impact of the barbecue, particularly when little or no shrubbery or trees are available as natural background. For houses that are one of five or more to an acre, houses on pipe stems, and houses on ul-de-sacs, permanent barbecues will be considered on a case-by-case basis. The major considerations shall be location and infringement on the neighbors' views.

Application Contents - site plat (other), color photo of affected area, dimensions, elevation, materials, and color

6. Barbecues, permanent (townhouse)

Permanent barbecues shall be placed in the rear yard, 10 feet from side property lines or, if that is not possible, equally distant from both side property lines. Permanent barbecues shall be placed no less than 15 feet from the house and 5 feet from the rear property line. The side fences shall be extended so that the barbecue does not protrude beyond them. Maximum height is 5 feet. If there is no rear property line fence, supplemental planting should be provided to soften the visual impact of the barbecue. Permanent barbecues will be considered on a case-by-case basis. The major considerations shall be location and infringement on the neighbors' views.

Application contents - site plat (other), color photo of affected area, dimensions, elevation, materials, and color

7. Addition of a basement emergency exit (non-walk out basement) (single family, manor home and townhouse)

Building codes are now requiring proper emergency exits from basements and proper emergency entry for firemen and other rescue workers in the event of a basement fire. Building permits for basement remodeling now require that such exits be installed. For more information on obtaining a Loudoun County building permit please see <http://www.loudoun.gov/Default.aspx?tabid=683>

Link for review - <http://www.loudoun.gov/documentcenter/view/897>

The installation of a Basement Emergency Exit must be approved by the DRC. There are two types of emergency exit systems that may be installed:

1. An egress window well
2. A door with a stairwell.

An egress window well is large enough to allow an adult to crawl out of the window and then stand up in the window well. The well should be no more than four feet deep. Egress window wells and steps must comply with the state and county building codes and shall be compatible with the architectural design and scale of the home.

Location

Basement Emergency Exits shall be located on the side or rear of the house. If steps are being installed on the side of the house, they must run parallel to the foundation wall. Steps installed at the rear of the house may run either parallel or perpendicular to the foundation wall.

Height

Basement doors and windows may not exceed the height of the sill plate or cannot cross into the siding of the house (door & windows must be below the bottom of the siding).

Materials

Egress windows wells may be made of concrete, composite, or metal. Steps must be of concrete or composite. Railings may be metal, composite or wood.

Application Contents - site plat (addition), color photo of affected area, dimensions, elevation, materials, color, and style of house.

8. Chimneys and metal flues (single family, townhouse, and manor home)

Chimneys shall be either made of or faced with brick or stone (to match any existing masonry on the house) or faced with the same material as the exterior of the building. Chimneys visible from the street shall be of the same type of material as chimneys on other similar homes in the immediate neighborhood. They shall be compatible in design and color with the existing house. Metal flues that penetrate the roof shall be either flat black or whatever color is commercially available that most closely matches the roof color.

Application Content- site plat (other), color photo of affected area, dimensions, elevation, materials, color, and style of house

9. Color changes (single family)

Repainting or staining to match original colors does not require an application. Changes of exterior color shall be aesthetically harmonious with other houses in the immediate area and with the roof and siding color of the house. When making color selection, please refer to McCormick's "Colonial Exterior Colors", which are the original exterior colors used in most of CountrySide. Any variation from the McCormick colors will be reviewed on a case-by-case basis. Adjacent homes of the exact same design shall not duplicate color schemes. Color changes shall also be compatible with the architecture of the house. Colors for trim and shutters of Tudor style houses shall be limited to shades of brown and grey; color of stucco shall be limited to shades of white and beige. However, such changes to Tudor homes shall still require application.

Repainting of foundation walls shall match closely to the current siding color and does not require an application.

Application Contents -listed on *Color Change Application Checklist* in Appendix B.

10. Color changes (townhouse)

When making a color selection, please refer to McCormick's "Colonial Exterior Colors", which are the original exterior colors used in most of CountrySide. Any variation from the McCormick colors will be reviewed on a case-by-case basis. Repainting of foundation walls shall match closely to the current siding color and does not require an application.

Globe Colonials (Foxfield and Welbourne)

Trim color is white (i.e., pure white, without tint), and no change is permitted. Color of doors, shutters, roofs, and siding may be changed. Such color change shall be aesthetically harmonious with other houses in the neighborhood, and compatible with the other colors on the townhouse.

Scarborough (Welbourne and Morven)

The only color change permitted is to doors.

Globe Tudors (Morven and Oakridge)

The only color change permitted is to doors.

Globe Georgian Woods Colonials (Oakridge)

Trim color is white, and no change is permitted. **No change is permitted to roof color.** Door and shutter colors may be changed provided: the door and shutters are both changed to the same color; the color is not the same as the neighboring townhouse on either side (this includes end units); and the change is to one of the approved Georgian Woods colors.

Application Contents -listed on *Color Change Application Checklist* in Appendix B, color photo of affected area.

11. Color changes (manor homes)

Manor homes were designed to look like single family homes. Therefore, any change in color must meet the criteria for single family houses and shall be made on both sides of the house and at the same time. The entire building shall always be painted the same color on one side as on the other side.

Repainting of entire foundation shall match current color of siding and does not require application.

Application Contents -listed on *Color Change Application Checklist* in Appendix B,
color photo of affected area

12. Compost bins (single family and manor home)

Visual and physical impact of the compost bin on neighbors will be taken into consideration. Screening with landscaping is suggested. Compost bins are not permitted in townhouse yards.

Location and Size

Compost bins shall be located in the rear of the lot, no less than 10 feet from neighboring homes. Size shall be compatible with lot size. Height shall not exceed 4 feet.

Materials and Color

Homeowner constructed compost bins shall be made of unpainted, pressure treated or other naturally weather resistant wood, and/or wire mesh which shall be brown or dark green, vinyl-coated, and 2" by 3" rectilinear in composition. Commercially produced compost bins may be of other materials and shall be unobtrusive in color, preferably dark green, dark brown, or black.

Maintenance and Upkeep

Proper composting techniques, cover, and enclosure shall be always used to prevent odors. All compost piles must be maintained and turned periodically to ensure the proper destruction of bacteria. Failure to maintain a satisfactory compost pile and/or the point at which the compost pile becomes a public nuisance shall indicate the abandonment of the compost pile and is a violation of these Guidelines.

Application Contents - site plat (other), color photo of affected area, dimensions, elevation, materials, and color

13. Decks (single family and manor home)

Decks are raised extensions of the house and thus have significant visual and physical impact on its appearance. Decks may also affect the privacy of adjacent properties. These two factors are weighted heavily in the review of applications. Equal consideration shall be given to one homeowner's right to privacy and an adjacent homeowner's right to enjoy his or her yard.

The following deck enhancements should be included on the same application as the deck planned at the same time: gazebo, screened porch, lights located on deck; shed under deck; lattice below deck level; privacy screen on deck; permanent flower boxes on railing; overhead trellis. Approval of other exterior modifications relating to the deck, such as new door and window locations and landscape lighting around the deck will be considered under separate application, contingent upon approval of the deck. Decks shall be constructed so as to appear plumb and level.

Location

Decks are to be located in the rear yard. However, side yard locations will be considered on a case-by-case basis. Privacy of adjacent homes shall be considered when planning decks. In reviewing applications for new and modified decks for homes on pipestems, Cul-de-sacs, and other small or unusually situated lots, very serious consideration shall be given to the balance between one homeowner's right to privacy and the adjacent homeowner's right to enjoy his or her yard. Deck shadow patterns affecting adjacent properties shall be considered both for their effect on the use of outdoor space and on grass and plant material.

Design

A good rule of thumb for relating deck size to house size is to make deck levels or functional areas roughly equal to average room size of the house. The architectural design shall be compatible with house design, lot configuration, and size of yard. Decks, particularly elevated decks, should be of a scale and style which are compatible with the home to which attached, adjacent homes, and the environmental surroundings. Deck railings shall not begin or end anywhere within the area occupied by a door or window. Stair railing design should be identical to the

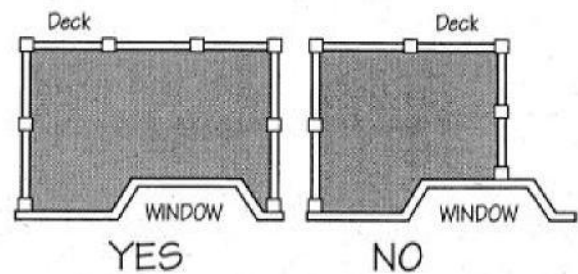

predominant design of the deck railing. Deck railing height shall be no less than 36” inches and no more than 42” inches and will be considered on a case-by-case basis.

Cantilevering or planting at post foundations should be provided on low decks to screen other structural elements and to soften visual impact.

Lattice and Privacy Screens

- All lattice below deck level should be softened with landscaping. Any lattice higher than 8 feet shall be considered on an individual basis and, if approved, shall require softening with landscaping.
- Privacy screens shall be no higher than 8 feet above the deck floor, whether lattice or other type. Except for hot tub enclosures, decks shall not be entirely enclosed with privacy screening.
- Any lattice used above deck level shall be framed along all edges (including where two pieces are connected) on the outward-facing side.
- Lattice is not a structural material and therefore not an appropriate substitute for railings. However, lattice may be placed inside a railing to provide safety or privacy.
- See also reference to lattice below in "Under-Deck Storage and Sheds."

Overhead Trellis

- An overhead trellis is an open, wooden structure designed to provide screening from the sun.
- The overhead structure shall consist of lathing (wooden slats) or framed lattice.
- The trellis shall be compatible with the house and deck in terms of scale and architectural style.
- The trellis shall match the deck in material, color, and design of railings and trim.
- Trellis shall not begin or end anywhere within the area occupied by a window or door.
- Overhead trellis shall not be covered with non-plant material.

Under-Deck Storage and Under-Deck Sheds

- Any solid wood door or wall placed below deck level, enclosing all or part of an under- deck area to conceal a storage area, shall be covered with lattice and shall be part of a complete under-deck lattice screening.
- When using an under-deck area for storage, the storage area shall be maintained to present a neat, uncluttered appearance.
- Solid walls are considered a shed and shall be integral and compatible with the deck.
- Color scheme shall be compatible with the deck.

On-Deck Lighting

- Low voltage lighting (12 volts) shall be used.
- All lighting shall be non-invasive to neighboring properties and to common area.
- Soft and subtle lighting is encouraged.
- Lights shall be placed below railing level.

Materials and Color

Wood shall be pressure-treated or naturally weather resistant (e.g., redwood or cedar). Stains of natural wood colors or paints matching a neutral (shades of white, beige, or gray) trim or dominant color of the house are acceptable but will be considered on an individual basis. Wood left to weather naturally is always an acceptable option. **Synthetic and plastic materials for deck flooring and railings may be approved on a case-by-case basis.** Use of other materials shall be considered on a case-by-case basis.

Drainage

If changes in grade or other conditions which will affect drainage are anticipated, they must be indicated on the application. All drainage problems, whether anticipated or not, shall be corrected by the homeowner responsible for the problem.

Modifications of Existing Decks

The above sections on Design, Location, Materials and Color, and Drainage apply also to all modifications. Sections of privacy railing and/or screening to be added to a deck that currently has none, shall be compatible in design with the existing railing.

Application Contents - listed on *Deck Application Checklist* in Appendix B, color photo of affected area

14. Decks (townhouse)

If you wish to apply for a standard deck, please see *Requirements for Standard Townhouse Decks and Patios* in Appendix A and the *Standard Townhouse Deck/Patio Application Checklist* in Appendix B. If your proposed deck does not fit the requirements of a standard deck, then the guidelines below apply, and your application must go through the full review process.

Location

Decks are to be located in the rear yard and a minimum of 1 foot from the side property line. End units may have decks extended to the side, along the rear plane of the house. Width of side extension will be considered on a case-by-case basis. End units may also have walkways, steps, and ramps against the side of the house, extending no farther forward than the front of the house. Such side extensions will be considered on a case-by-case basis. Raised decks shall extend no farther back than 1/2 of the rear yard.

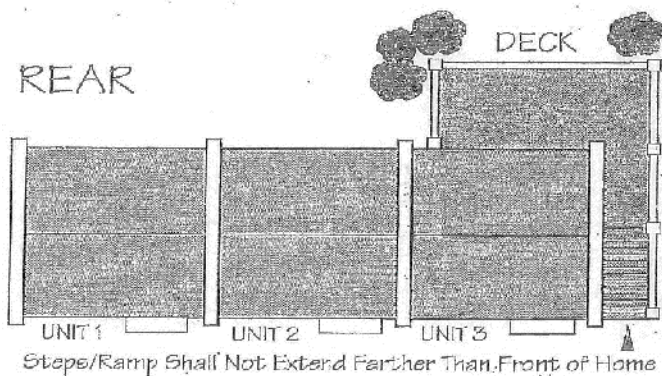

Design

Decks, particularly elevated decks, should be of a scale and style which are compatible with the home to which attached. Deck railings shall not begin or end anywhere within the area occupied by a door or window. Stair railing design should be identical to the predominant design of the deck railing. Height shall be no less than 36 inches and no more than 42 inches and will be considered on a case-by-case basis. Cantilevering or planting shall be provided at post foundations and on low decks to screen other structural elements and to soften visual impact.

Lattice and Privacy Screens

- All lattice below deck level should be softened landscaping. Any lattice higher than 8 feet shall be considered on an individual basis and, if approved, shall require softening with landscaping.
- Lattice privacy screens are permitted but shall be no higher than 8 feet above the deck floor and shall extend no farther than 8 feet from the rear wall of the house.
- Any lattice used above deck level shall be framed along all edges (including where two pieces are connected) on the outward-facing side.
- Lattice is not a structural material and therefore not an appropriate substitute for railings. However, lattice may be placed inside a railing to provide safety or privacy.
- See also reference to lattice below in "Under-Deck Storage and Sheds."

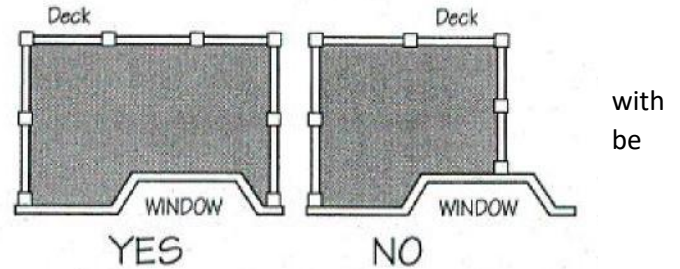

Under-Deck Storage and Under-Deck Sheds

- Any solid wood door or wall placed below deck level, enclosing all or part of an under-deck area to conceal a storage area, shall be covered with lattice and shall be part of a complete under-deck lattice screening.
- When using an under-deck area for storage, the storage area shall be maintained to present a neat, uncluttered appearance.

On-Deck Lighting

- Low voltage lighting (12 volts) shall be used.
- All lighting shall be non-invasive to neighboring properties and to common area.
- Soft and subtle lighting is encouraged.
- Lights shall be placed below railing level.

Overhead Trellis

- An overhead trellis is an open, wooden structure designed to provide screening from the sun.
- The overhead structure shall consist of lathing (wooden slats) or framed lattice.
- Potential shadowing of a neighbor's deck or yard shall be considered in the location of the overhead trellis.
- The trellis shall be compatible with the house and deck in terms of scale and architectural style.
- The trellis shall match the deck in material, color, and design of railings and trim.
- Trellis shall not begin or end anywhere within the area occupied by a window or door.
- Overhead trellis shall not be covered with non-plant material.

Materials and Color

Wood shall be pressure treated wood or naturally weather resistant (e.g., cedar or redwood) wood. *Stains of natural wood colors or paints matching a neutral (shades of white, beige, or gray) trim or dominant color of the house are acceptable but will be considered on an individual basis. Wood left to weather naturally is always an acceptable option. Synthetic and plastic materials for deck flooring and railings may be approved on a case-by-case basis. Use of other materials shall be considered on a case-by-case basis.*

Drainage

If changes in grade or conditions which will affect drainage are anticipated, they must be indicated on the application. All drainage problems, whether anticipated or not, shall be corrected by the homeowner responsible for the problem.

Modifications of Existing Decks

The above sections on Design, Location, Materials and Color, and Drainage apply also to all modifications. In addition, all modifications shall match the existing deck in all detailing such as materials, color, and the design of railings and trim. Sections of privacy railing and/or screening to be added to a deck that currently has none, shall be compatible in design with the existing railing.

Application Contents -listed on *Deck Application Checklist* in Appendix B, color photo of affected area

15. Decorative objects (single family, townhouse, and manor home)

Decorative objects, including but not limited to weathervanes, statuary, and fountains will be evaluated for general appropriateness, size, location, and design compatibility with the architecture of the house. The purpose of these guidelines for decorative objects is to maintain curb appeal for the benefit of all CountrySide homeowners. The guiding principle shall be the maintaining of an uncluttered and aesthetically pleasing yard.

Decorative objects that fit any one of the following three sets of criteria require application:

1. Any decorative object placed forward of the front fence line (a straight line drawn from the nearest front corner of each adjacent house to the nearest front corner of the applicant's house) and higher than 18" inches above ground or wider than 15" inches at the widest point.
2. Any object placed forward of the front fence line (as described above), AND smaller than 18" inches above ground or 15" inches across at the widest point (such as a grouping of small objects), WHICH IS the subject of a neighbor's complaint.
3. Any object placed in the rear yard (behind the front fence line as described above) and higher than 18 inches above ground or wider than 15" inches at the widest point and the subject of a neighbor's complaint (Objects which are placed in the rear yard and are smaller than 18" inches high or 15" inches wide will not, under any circumstances, require application).

Exceptions to the above requirement are listed below and **do not require application**:

1. All seasonal items (e.g., Christmas decorations) not permanently attached to any part of the house
2. All non-seasonal pottery, terra cotta, stone, concrete, and wood planters placed on stoops and entrance walks
3. All seasonal planters (including plain plastic pots) placed on stoops and entrance walks

The following are Guidelines for some common decorative objects.

Planters

Any kind of planter permanently attached to the house (such as window boxes and planters attached to the porch railing) shall require application. Such planters shall match one of the exterior house colors and be compatible with the house in design and scale.

Lawn Objects

All lawn objects (e.g., bird baths, cement animals) regardless of size, shall be part of a landscaping scheme which includes shrubs, trees, or groundcover other than grass (e.g., ivy, liriopé) in order to soften the visual impact of the object. "Part of a landscaping scheme" is defined as among or close to the plantings so as to appear part of a whole.

Application Contents- site plat (other) dimensions, color photo of affected area, elevation, materials, color, and style of house

16. Dog houses and dog runs (single family, townhouse, and manor home)

Dog houses shall be located within a fenced-in area or in the rear yard if there is no fence. Side yard placement generally is disfavored and shall be considered on a case-by-case basis for unusual lot configurations. In addition, placement shall be under or next to the deck; next to the house; or next to the fence. The objective is for dog houses to be located so as to be visually unobtrusive. Maximum height shall be 4' feet and roof slope should be consistent with that of the house.

Materials shall be pressure treated or other naturally weather resistant wood or siding that matches the house siding in color and style if the doghouse is placed adjacent to the house. If the doghouse is constructed of wood, it shall be painted, stained, or left to weather, whichever matches the structure adjacent to the doghouse. Dog runs and dog pens are prohibited.

Application Contents - site plat (addition), color photo of affected area, dimensions, elevation, materials, and color

17. Doors (single family, townhouse, and manor home)

Installation of storm doors and windows, screen doors, security doors and windows, and new and replacement doors will impact on the appearance of a dwelling. Consideration shall be given to the design of the particular door or window and its relationship to the design of the house and adjacent houses.

Combination storm-screen doors (all homes)

Design

Design shall be compatible with the design of the house. Bars, decorative scroll work, imitation gate hinges, and decorative figures are not acceptable.

Materials

Materials shall be metal or wood.

Storm or screen doors shall be painted the same color as the entry doors behind them or as the color of the architectural trim. Instances where color cannot be matched exactly will be considered on a case-by-case basis. Color shall not match house siding, which is different from the trim, unless allowed by neighborhood standards. Window

frames are not considered architectural trim. However, on those houses that have prominent brown window frames, storm doors may be the same shade of brown.

Neighborhood Standards

There are designated Standards for storm/screen doors in all seven neighborhoods of

CountrySide for single family houses and townhouses. (See Appendix A.) It is strongly recommended that all storm/screen doors adhere to the standard designs established by each CountrySide neighborhood. These neighborhood standards have been approved after careful thought and consideration regarding the maintenance of visual and architectural quality of our community.

Deviations from neighborhood standards require use of the full application and review process.

Wooden screen- only doors (all homes)

This subsection refers to wood-framed screen doors that are meant to be painted.

Location

Individual consideration shall be given for front screen doors on Victorian, farmhouse, and Colonial style houses with a covered porch. On all other types of houses, screen doors shall be located on the side and back of the house.

Design

Design shall be compatible with the design of the house. Decorative scroll work, imitation gate hinges, decorative figures, and plywood panels are not acceptable. Victorian gingerbread is appropriate for Victorian style homes.

Materials

Doors shall only be made of wood, and there shall be no "winterizing" of screen doors with Plexiglass or plastic.

Screen doors shall be painted the same color as the entry doors behind them or as the color of the architectural trim. Window frames are not considered architectural trim. However, on those houses that have prominent brown window frames, screen doors may be the same shade of brown. Color shall not match house siding, which is different from the trim, unless allowed by neighborhood guidelines.

Security doors (all homes)

A security door on the front of the house or visible from the street shall be without bars, scrollwork, or other ornamentation and shall match, in color, the door behind it. A door with bars or ornamentation is restricted to the rear of the house and shall match, in color (including bars and ornamentation), the door behind it. Instances where color cannot be matched exactly will be considered on a case-by-case basis. For below-ground security doors on the rear of the house, bars are acceptable and there are no color matching requirements.

Replacement doors (single family)

This subsection covers the replacement of a door with one of a different design or color. No application is required for replacement with the same color.

Front facing and main entry doors

DESIGN

Design shall be compatible with the architectural design of the house. The design of the door shall not disturb the harmony and balance of the exterior appearance of the house. Below are some examples of what would be considered inappropriate door selections:

- Suncatcher- no Victorian oval or six panel

- Victorian- no plain, flat contemporary
- Colonial or Traditional - no plain, flat contemporary or Victorian oval
- Tudor- no plain, flat contemporary or Victorian oval

MATERIALS

Materials shall be wood, *fiberglass*, or metal with or without glass inserts.

Color of the replacement door shall be compatible with the shutters, trim, siding, roof, brick or stone, and architectural design of the house. See also the section on **COLOR CHANGES**.

Side and rear doors

DESIGN

Design shall be compatible with the architecture of the house.

MATERIALS

Materials shall be wood, fiberglass, or metal with or without glass inserts.

Color shall match trim color of the house or be of the same color as the door being replaced.

Replacement doors (manor home)

The design, materials, and color of all replacement doors for manor homes shall be the same as the original doors and do not require application. Replacement doors that are not an exact match in color, material and design as the original door are subject to the formal committee review. For color changes, see **COLOR CHANGES**.

Design

Design shall be compatible with the architectural design of the house. The design of the door shall not disturb the harmony and balance of the exterior appearance of the house.

Application Contents- dimensions, elevation, materials, color, color photo of affected area, and style of house.

Replacement doors (townhouse)

The design, material, and color of all replacement doors for townhouses require application. For color changes, see **COLOR CHANGES**.

There are designated "standards" for entry doors for all townhouse communities to include Foxfield, Morven, Oakridge and Welbourne. (See Appendix A).

Application Contents- dimensions, elevation, materials, color, color photo of affected area, and style of house.

Additional doors (single family)

Design and Location

Design and location of additional doors shall be compatible with the architectural design of the house and shall not disturb the harmony and balance of the exterior appearance of the house. The effect of additional doors on neighbors' privacy shall be considered.

Materials

Materials shall be wood, fiberglass or metal with or without glass inserts.

Color

Additional front-facing or main entry doors shall match front-facing or main entry doors. The color of additional side or rear doors shall match that of existing side or rear doors. In the case of doors that are being moved from one location to another, the color guidelines for Replacement Doors shall apply.

Application Contents- color photo of affected area, dimensions, elevation, materials, color, and style of house

18. Driveways and driveway extensions

Driveways

Replacement or repair of a driveway does not require DRC approval if the size remains the same and it is replaced with the same materials as the original driveway. Any material changes require DRC approval.

Extensions and Parking Pads

Extension of a driveway to accommodate an extra vehicle will be considered on a case by-case basis considering it does not have a negative impact on the neighborhood setting (e.g., creation of drainage problems, extensions disproportionate to lot size etc.) Any extension shall not alter the drainage pattern to cause additional drainage onto neighboring properties.

The extension shall be no wider than 8 feet and no closer to the adjacent property line than 1 1/2 feet. It shall be contiguous to and made of the same materials as the existing driveway.

Application Contents - site plat showing the addition, color photo of affected area, dimensions, materials, and color (if applicable).

19. Entrance walks (single family and manor homes)

Walkways or paths shall not extend directly from the side yard to the public sidewalk or street unless they are attached to and run down the side of the driveway.

Walkways extending from the driveway or front entrance around the side of the house shall be set back a minimum of 1 foot from side property lines. Any new or extended walkways shall not alter the drainage pattern to cause additional drainage on to neighboring properties.

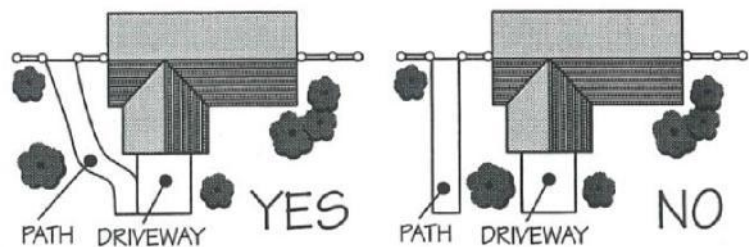

With respect to the replacement of existing walkways and the installation of new walkways or paths, the type and color of materials, scale, location, and design shall be compatible with the lot, home, and surroundings. Also, walkway shall be installed flush to the existing ground except where steps are required, or drainage would be negatively affected. Any walkway consistent with the "Standard for Walkways" would not be subject to the formal review process.

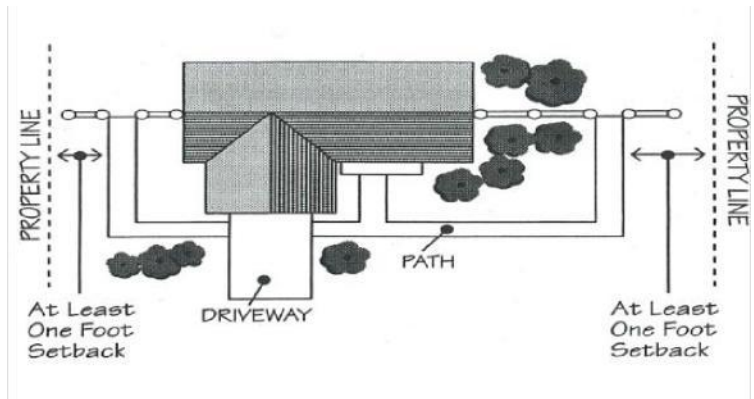

Exceptions may be made to any part of this guideline to facilitate handicapped access.

Application Contents - site plat (addition), color photo of affected area, dimensions, elevation, materials, and color

20. Entrance walks (townhouse)

Additions to entrance walks are permitted on end units only. Walkways shall not extend directly from the side yard to the public sidewalk unless a parking area is located straight out from a side-facing main entrance.

Walkways extending from the front walk around the side of the block of townhouses and to the rear yard of the end unit shall be set back a minimum of 1 (one) foot from the side property line.

Walkways shall be installed flush to the existing ground, except where steps are required, or drainage would be negatively affected. Any new or extended walkways shall not alter the drainage pattern to cause additional drainage onto neighboring properties.

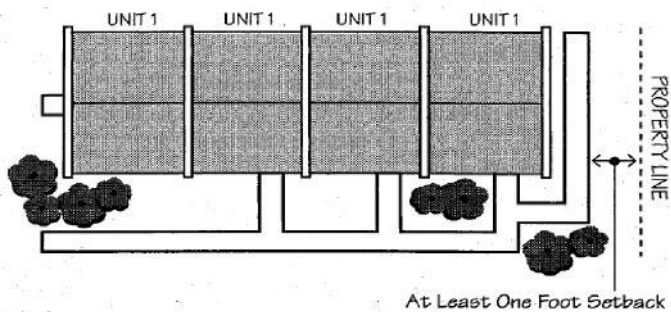
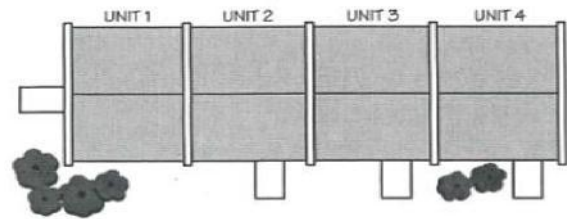

For the installation of new walkways, the type and color of materials, scale, location, and design shall be compatible with the townhouse. With respect to the replacement of walkways, the materials, location, and design shall be identical to the walkway being replaced, if it is an original, main entrance walkway. Replacement of a previously added walkway around an end unit shall be compatible with the townhouse in materials, scale, location, design, and color.

Identical walkway replacements do not require application. Any walkway consistent with the "Standard for Walkways" would not be subject to the formal review process.

Concrete Coatings, acrylic coatings or sealants on an existing walkway, stoop or steps will be reviewed on a case-by-case basis. These materials require an application and submittal of a sample of the proposed finish and color. The color and texture should match closely as possible to the adjacent common area sidewalk.

Exceptions may be made to any part of this guideline to facilitate handicapped access.

Application Contents - site plat (addition), color photo of affected area, dimensions, elevation, materials, and color

21. EV, Electric Vehicle Charging Stations, or Boxes (single family, townhouse, and manor home)

Townhouse

EV, Electric Vehicle charging stations or boxes require an application and will be reviewed on a case-by-case basis.

Application Requirements- site plat, color photo of affected area, product information including, color, style, dimensions, material and color and style of the house.

Single Family and Manor Home

EV, Electric Vehicle charging stations or boxes require an application. The application must meet the following criteria.

- The charging station or box does not have an adverse visual impact on neighboring properties
- The charging station or box shall be obscured from the view of all neighboring properties and roads
- The applicant is responsible to ensure that local electrical codes and permitting requirements are met.

Application Requirements- site plat, color photo of affected area, product information including, color, style, dimensions, material, color, and style of the house.

22. Fences (single family, townhouse, and manor homes)

All fences, including fence posts, shall be pressure treated wood or naturally weathered resistant wood. *Non-wood substitute fencing materials, such as pre-built vinyl board or other exotic materials, shall be approved on a case-by-case basis consistent with other existing guidelines. Uniform materials shall be used throughout the entire length of fencing. **No permanent masonry will be allowed above grade along property lines or along sight lines.***

Homeowners should remember that there are alternatives to fencing that may achieve the needed results. Use of plant material alone can be an alternative. Common area provides residential lots with the atmosphere of larger open areas. Fencing, if it is carelessly used or placed, encroaches upon this open space atmosphere, and can even destroy it.

Proper fencing can have a unifying effect upon a neighborhood. Cluttering a neighborhood with an uncoordinated selection and placement of fences should be avoided. Cooperation among neighbors in this matter can affect the visual and psychological harmony of an area.

The following sections are applicable to single family homes and manor homes. A separate section for townhouses follows these.

Single family and manor home fencing

Location

In order to prevent double fencing, new fences shall share existing fencing along adjacent property lines.

All fencing shall be within 1" inch of property line, except as specified below:

- around electric, phone, and cable boxes and other permanent obstructions not under the homeowner's control
- around swimming pools - However, non-property line fencing surrounding a swimming pool shall not be so close to an adjacent property as to create an alley.
- around patios
- bordering pipe-stem drives - This type of fencing should be set back from common driveway, preferably 4 feet where space permits, but no less than 2 feet on smaller lots, and softened with landscaping.
- on corner lots - See Corner Lots, below.
- along the Sight Line, as described below.

Sight Line - Except as noted below under Corner Lots and Irregular and Small Lots, an applicant's fence shall not extend forward of a straight line drawn from the nearest front corner of each adjacent residence to the nearest front corner of the applicant's residence. Where the above-mentioned line passes through an adjacent residence, the line will terminate at the nearest rear corner of said residence.

The policy of the Proprietary is to keep fencing from obstructing an adjacent home's view of the street any more than the applicant's home restricts that view.

Front yard fencing will be permitted only under special circumstances. Some fences which appear to be in a neighbor's front yard due to lot configuration (such as on pipestems) will be reviewed on a case-by-case basis.

Corner Lots - It is preferred that corner lot fencing not extend closer to either street than the closest point of the house to that street. However, corner lot fencing may be allowed to extend into side yards if it does not extend more than one half the distance to the property line or no less than 10 feet from the property line and when the side yard does not abut the front yard of a neighboring property.

Relationship to adjacent houses and other site factors (such as hills and gullies that raise or lower the fence out of the sight line) will also be considered in determining fencing locations.

Fence Location Diagram

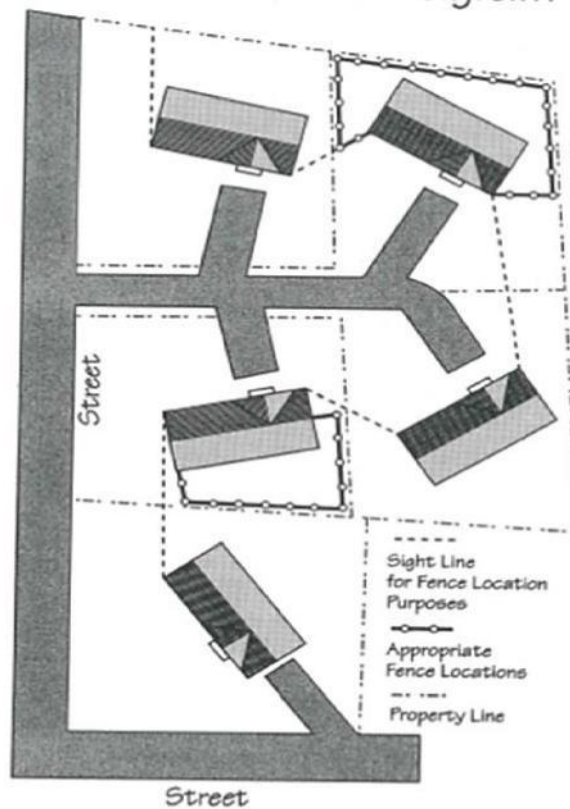

Irregular and Small Lots Individual consideration will be given to unusual lot configurations, pipe stems, small corner lots, and Cul-de-sacs. A small lot is defined as one of 5 or more lots per acre.

Fencing bordering pipe stem drives shall be set back, preferably, 4 feet from the common driveway, where space permits, but no less than 2 feet on small lots, and softened with landscaping.

Privacy Fencing- Privacy fencing shall be 6 feet in height. Fence style shall be board-on-board or "shadowbox" and shall be pressure treated wood and is restricted to:

- Swimming Pools - If screening from the street is desired, limited privacy fencing may be allowed. Such privacy fencing shall extend from the side of the house to the property line and extend no further than 16 feet along the property line toward the rear.
- Patios - Privacy fencing may surround a patio which adjoins the rear of a house. Privacy fencing surrounding a Patio shall extend no farther than 3' (feet) from all sides of the Patio edge.
- Manor Homes - Common property line privacy fencing between the two halves of one building shall extend no further than 16 feet from the rear wall of the house.

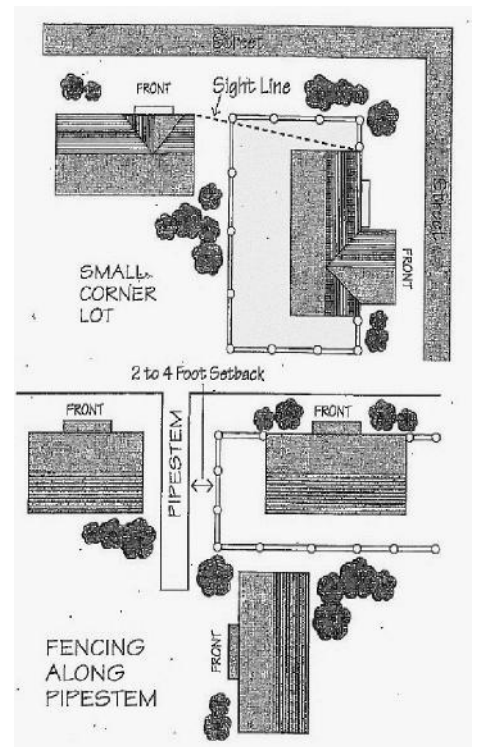

Design

Property line fence styles are limited to picket, split rail, and estate and shall not exceed 48 inches in height. Strictly limited use of privacy fencing is permitted. See **Privacy Fencing** above. Appendix D contains illustrations of fence styles.

Fencing should match or blend in design and height with existing adjacent fencing. "Adjacent" shall be defined as: "directly next to," where no other property, such as a pipestem or common area comes in between the two properties.

Fencing on both sides of one Manor Home building shall match in design.

Fencing which is finished on one side only shall be constructed with the finished side facing out.

Gates shall be compatible with fencing in design, material, height, and color. Gate hardware shall be unobtrusive and rust resistant.

Wire mesh may be used in conjunction with lot-line fences to enclose the lot for pets and small children. Wire mesh shall be brown or dark green, or black vinyl-coated, and may be galvanized. Wire mesh shall be no less than 14 gauge and 2" inch by 3" inch rectilinear in composition. The wire mesh shall be attached on the inside of the fence and shall not extend above the top rail.

The bottom of split rail fences shall be no more than 18" inches above grade at any point.

All other types of fencing shall be no more than 4" inches above grade at any point. If the ground slopes, privacy fencing shall be stepped, all other types of fencing shall follow the contour of the land.

Materials

All fences, including fence posts, shall be pressure treated wood or naturally weather resistant wood. ***No permanent masonry will be allowed above grade along property lines or along sight line.***

Fencing on both sides of a **Manor Home** building shall match in design, materials, and color.

Color

It is recommended that the wood be allowed to weather naturally. Stains or paints will be considered on an individual basis. Natural wood tones are preferred, but others will be considered on an individual basis. Fence color should match or blend with existing adjacent fencing.

Fencing on both sides of a **Manor Home** shall match in design, materials, and color.

Maintenance

Fencing shall be built plumb and level and kept in good repair.

Townhouse fencing

Design, Materials, and Color

Fence style, material, and color shall match, in all relevant details, that which has been provided by the builder. Stains of natural wood colors or paints matching a neutral (shades of white, beige, or gray) trim or dominant color of the house are acceptable but will be considered on an individual basis. Approved color changes shall treat the entire Fence including shared Fence panels.

If the ground slopes, fencing shall be stepped.

Location

Fencing shall be in the rear yard of property except for end units.

End units may extend the fence to the side property line at a point halfway between the front and back of the building.

Application Contents - listed on *Fence Application Checklist* in Appendix B. See "standard" fence and gate style in Appendix A, color photo of affected area.

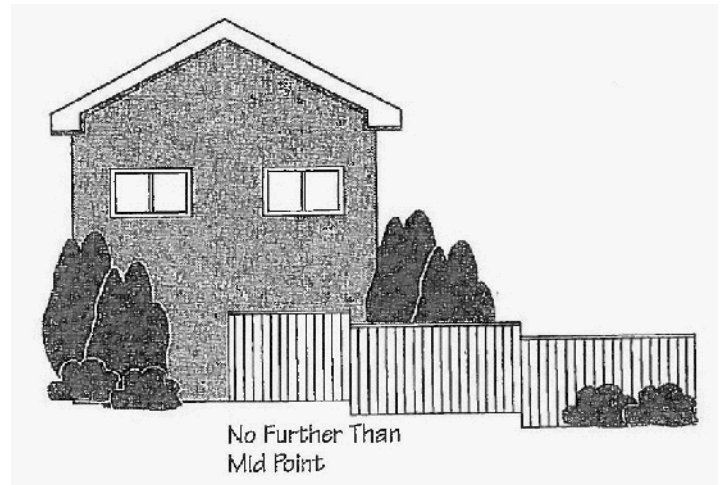

23. Firewood (single family, townhouse, and manor home)

Application shall be required for woodpiles in excess of 2 cords. (One cord is a stack that measures 4 feet by 4 feet by 8 feet). Woodpiles shall not exceed 4 feet in height and shall contain firewood only. The woodpile shall be located in such a manner as to avoid adverse visual impact. Screening with landscaping may be required as a condition to approval of woodpiles in excess of 2 cords.

The location of woodpiles for homes on pipe stems, cui-de-sacs, and other small and/or unusually situated lots should be viewed with equal consideration given to the homeowner's practical needs and the neighbor's right to a clear and uncluttered view. No woodpile shall be kept on common ground. See also *Maintenance Guidelines*

Application Contents - site plat (other), color photo of affected area, dimensions

24. Garage renovation

The exterior design of garage renovations shall be compatible in scale, materials, and color with the applicant's house.

Application Contents- site plat (other), color photo of affected area, dimensions, elevation, materials, color, style of house

25. Garden trellises and arbors (single family, townhouse, and manor house)

This section pertains to garden trellises and arbors that form landscape structures. For trellises used as sun control devices, see the subsection on "Overhead Trellis" under **DECKS** or **PATIO**s. A trellis is a flat support structure for plant material. An arbor is a free-standing structure or can be part of a fence. An application is not required for garden trellises. All arbors require an application. The following guidelines apply to all garden trellises and arbors, whether an application is required or not.

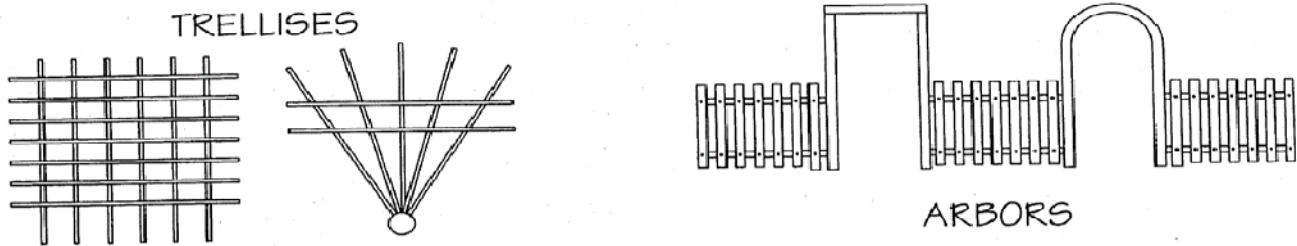

Location (single family and manor house)

Garden trellises shall normally be limited to the side or rear of the house. However, the style of the house may permit locating the trellis in the front of the house, i.e., on a chimney or a Suncatcher where the chimney is on the front of the house. Arbors are to be located on the side or rear only, behind the front fence line.

Design (single family and manor home)

Garden trellises and arbors shall be compatible with the house and lot in terms of style and scale. All lattice used shall be framed along all edges on the side(s) facing out. Garden trellises and arbors shall not be covered with non-plant material.

Location (townhouse)

Garden trellises shall normally be limited to the side or rear of the house. However, the style of the house may permit locating the trellis in the front of the house, i.e., on the plain, street side or the door side of the end unit of a townhouse where the door is located on the side. Arbors are to be located in the rear or side yard only. An arbor along the property line shall be incorporated into an approved privacy fence.

Design (townhouse)

A block of townhouses is designed as a unit. Therefore, there must be a consistency of design in any exterior modifications or additions. That is the rationale for the fencing guidelines, which require all townhouse fences to be privacy fences, matching the builder-provided fences. Consequently, if an arbor is to be placed along the property line, it must be integrated into an approved fence. Height, in that case, will be limited to 7 (seven) feet. Garden trellises shall be compatible with the house and lot in terms of style and scale. All lattice used shall be framed along all edges on the side(s) facing out. Garden trellises and arbors shall not be covered with non-plant material.

Materials

All trellises and arbors shall be of pressure treated or naturally weather resistant wood or vinyl.

Color

Trellises attached to or up against the house or building shall: be left to weather naturally; be painted to match neutral-colored (shades of white, beige, or gray) trim or siding; or be painted to match the siding to which it's attached.

A free-standing trellis or arbor shall be part of a landscaping scheme. It is recommended that wood be allowed to weather naturally. Stains or paint will be considered on an individual basis. If a fence exists, a free-standing garden trellis or arbor of constructed wood shall match the color of the fence. A garden trellis or arbor attached to or placed next to a fence or deck shall match the color of the fence or deck.

Application Contents -site plat (addition), color photo of affected area, dimensions, elevation, materials, color, style of house

26. Gazebos (single family)

A gazebo is a structure which may or may not be enclosed by screens. It does not have windows. A gazebo has a roof which may or may not have skylights.

Design

The slope of the roof shall match the slope of the house roof. If there are existing turrets or other gazebos on the same property, the slope of the roof shall match these to the closest extent possible.

Gazebo railing shall match deck railing. Screen doors and trim detail shall be compatible with the architectural design of the house. (For example, Victorian gingerbread trim is not appropriate on either a contemporary or Colonial style house.)

Location and Site

Location shall not impair the views or the amount of sunlight and natural ventilation reaching adjacent properties. Gazebos shall **either** be attached to the deck in rear of house **or located in the rear yard attached to the ground. If located on the deck, it shall be apart from the house.** The size of all gazebos shall be in proportion to the lot and house size. It shall be set apart from the house and located on or near the outer edges of the deck so that the gazebo roof is significantly separated from the house.

Materials

Roof shall match that on the house. Exceptions will be considered on a case-by-case basis. Screens shall match existing screens. The frame shall be pressure treated or naturally weather-resistant wood. **Other man-made materials such as composites and vinyl will be approved on a case-by-case basis. Screen doors frames shall be of the same material as the gazebo.** Winterizing screens with plastic or Plexiglass is prohibited.

Color

Wood may be left to weather naturally or may be painted or stained to match deck. The color of screens and roof shingles shall be the same as the screens and roof shingles, respectively, or the house.

Application Contents -site plat (addition), color photo of affected area, dimensions, elevation, materials, color, style of house

27. Gazebos (townhouse)

Gazebos on townhouses are prohibited.

28. Generators (single family, townhouse, and Manor home)

Permanent generators must be located on the side or rear of the house and must be screened by shrubs or hedging, consistent with the performance and ventilation requirements of the unit. Permanently installed generators must not exceed 70 db.

Homeowners are responsible for complying with the Loudoun County Noise ordinance.

Application Contents- site plat, color photo of affected area, dimensions, elevation, and product information

29. Greenhouses (single family, townhouse, and manor home)

Greenhouses and conservatories are distinguished from sunrooms and other additions to the primary structure by the vast amount of glass used. In greenhouses and conservatories, the roof and the major portion of the exterior walls are made of glass. There may be a knee wall, above which there is only glass and frame, or the entire structure may be glass and frame. A greenhouse is a simple, straightforward design which is appropriate for any style of house. A conservatory is a decorative structure with distinct traditional elements which make it unsuitable for a contemporary house such as a Suncatcher.

Greenhouses and conservatories (hereinafter referred to as "greenhouses") are an extension of the house and thus have significant impact on its appearance. The addition of a greenhouse may also affect the privacy of adjacent properties. These two factors will be weighted heavily in the review of applications.

Single family and manor home greenhouses

Location

A greenhouse shall be attached to the rear of the house, although in special instances, side yard locations will be considered on a case-by-case basis (southern exposure will not be the sole consideration).

Design

The proposed structure shall be architecturally compatible with the existing structure and shall not be too large in relation to the house, the lot, or adjacent houses.

Materials and Color

Knee wall materials shall match (in color, composition, and style) the primary structure materials to which they are attached.

Townhouse greenhouses

Location

A greenhouse shall be attached to the rear of the house at ground level. Side yard greenhouses on end units shall be considered based on visibility and impact on neighbors

Design

The proposed structure shall be a simple, straightforward design with a shed roof or shed-type curved roof. Side property line fencing shall extend at least as far into the rear yard as the greenhouse so that no portion of the greenhouse extends beyond the side fencing.

Application Contents -site plat (addition), color photo of affected area, dimensions, elevation, materials, color, and style of house

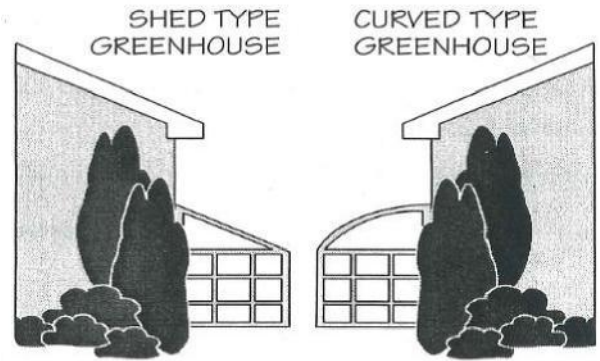

30. Gutters and downspouts (single family, townhouse, and manor home)

Gutters and downspouts shall match those already existing in color and design. *Material may be either metal or vinyl. The addition of gutter caps and/or gutter guards is acceptable provided they are aesthetically pleasing to the house and are of the same color as the existing gutter(s). The Design Review Coordinator may consider replacement of gutters, downspouts and the installation of gutter caps and guards as a "standard" application for approval.*

Color

If the house color changes, the gutters and downspouts shall match the siding and/or trim color of the house. Changes in location of downspouts or addition of downspouts shall not alter the drainage pattern so as to cause additional drainage onto neighboring properties.

Application Contents - site plat (other), color photo of affected area, dimensions, photo of home, elevation, materials, color

31. Hot tubs and spas (single family, townhouse, and manor home)

Exterior hot tubs and spas shall be located in the rear yard adjacent to the dwelling unit or incorporated as an architectural feature of a deck or patio. The exterior finish shall be a neutral color. *The tub must be screened with lattice or approved landscaping. Deviations will be reviewed on a case-by-case basis.*

Application Contents - site plat (other), color photo of affected area, dimensions, elevation, materials, color

32. Landscaping (single family, townhouse, and manor home)

CountrySide is located in an area characterized by woodlands and rolling pastureland. The natural beauty of this land was carefully preserved during development. In keeping with this history, it is recognized that landscaping affects the visual harmony of CountrySide, as a whole. The function of the landscaping guidelines is to protect homeowners from extreme landscape schemes and to preserve the curb appeal of our neighborhoods.

The following three subsections will be covered: Changes Requiring Application; Requirements; and Suggestions.

Change requiring application

All landscape designs that include any one of the following **REQUIRE APPLICATION**:

1. The use of **non-plant** materials greater than 18 inches in height (See **Non-Plant Materials** below.)

2. For single family and manor homes only: a significant alteration of the current landscape scheme in a front yard or, on a corner lot, on the front and side yard - "Significant alteration" includes but is not limited to: A) the removal or planned removal of grass on a total of more than one half of the front yard (or front and side yard on a corner lot). The area of the driveway and a foundation planting area extending 4 feet from the house and 4 feet on both sides of the entrance walk are not included when determining what is more than one half of the front yard. B) the addition of plantings that will form a visual barrier along any part of the front yard property line or become, in effect, a fence. (See **Front Yard** below).

If the application is otherwise acceptable, any such plantings shall be maintained so as not to exceed three feet in width and five feet in height.

3. The inclusion of any permanent masonry, in any part of the yard, regardless of height (for example: stone or brick walls)
4. Landscaping or maintaining of common area requires application

Non-Plant Materials

A landscape scheme that includes the use of any non-plant material (such as rocks, railroad ties, lumber, brick, fencing, etc.) that is 18" or higher in any part of the yard, must go through the application process because the extensive use of non-plant material involves replacing the softness of greenery with a structural element. In the case of a tiered garden using non-plant materials, application shall be required when the vertical drop measures 18" or more from the top of the highest piece of non-plant material to the bottom of the lowest piece of non-plant material.

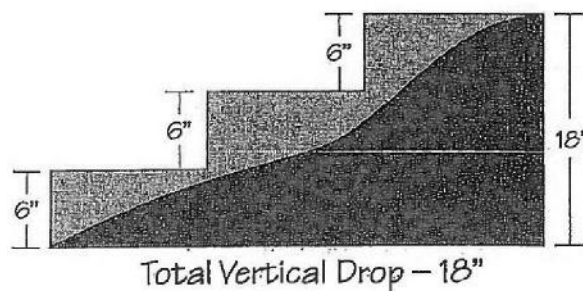

An application is required for any permanent masonry, regardless of height.

Front Yard (single family and manor homes only)

Significant alterations of the current landscape scheme require application. In considering such applications, the guiding principles will be Countryside's open space concept; the impact on adjacent properties; and a balance between the scale of the planted area and the scale of the house and yard. It is NOT the intention of the DRC to closely scrutinize landscape plans, but rather to assure that significant alterations to front and street side yards are the result of some planning AND are not extreme so as to adversely affect the value of neighboring properties. Some examples of what would be considered extreme are: filling the entire front yard of a single-family house with rose bushes or replacing all grass or groundcover with mulch and no other plantings.

"Significant alterations" include but are not limited to removal of large portions of grass, and addition of plantings that will form a visual barrier along any part of the front yard property line or become, in effect, a fence. "Removal of large portions of grass" shall be defined as the removal or planned removal of grass on a total of more than one half of the front yard (or front and side yard on a corner lot). The area of the driveway and a foundation planting area extending 4 feet from the house and 4 feet on both sides of the entrance walk are not included when determining what is more than one half of the front yard.

Requirements for all landscaping

Plantings shall not obstruct walkways or sight lines required for vehicular traffic. Decorative edgings are restricted to planting beds. Decorative edgings made of wire, plastic, and/or rubber tires are not permitted. This does not preclude the use of non-decorative lawn edging to separate grass from bedding areas.

The formation, on a yard, of letters or numbers using either plant or non-plant materials is prohibited.

Suggestions

Design

Landscaping can be effectively used to accent entryways, define space, create "soft" privacy screens, and reduce the visual impact of fences, sheds, etc. Since landscaping is a design element, the same consideration should be given to the relationship between the applicant's house and adjacent houses as is given to other design elements. In addition, the following elements within the landscape design should be given full consideration: balance, texture, color, form, and variety (neither too few nor too many). The goal of landscape design is the use of natural plants and trees within a harmonious design that is consistent with other lots in the neighborhood.

A good landscape design does not just happen, but rather requires some thought and careful consideration of design principles. While some homeowners may prefer to engage the services of a landscape designer or landscape architect, others may wish to do their own designing. Listed below are some design strategies to help with landscape planning.

- masses or groupings of trees and shrubs instead of lines of trees and shrubs
- plants clustered rather than widely spread
- tall plants in back, lower plants in front
- variation in size and shape of planting beds
- variation in size and shape of plants.

Decorative edgings should be of unpainted, pressure-treated wood, unpainted stones, or natural brick.

Care must be exercised in selecting plant materials, which, upon maturity, will be of an appropriate height and breadth for their intended use and location. Mature size, both in height and diameter, must always be considered, especially when planting close to walkways and neighboring houses and properties. Consideration shall be given to the effect which plantings will, in time, have on views from neighboring houses and property.

Maintenance

All planted areas should be neatly maintained throughout the growing season. This includes removal of all unused stakes and trellises) and dead growth. Trees and shrubs should be kept properly pruned. Dead trees and shrubs should be removed promptly.

Application Contents - site plat (other) drawn to scale; specify type of plants. Include dimensions, elevation, materials, and color for all structural elements, color photo of affected area.

33. Lighting (single family, townhouse, and manor homes)

There are three types of exterior lighting: Safety Lighting and Landscape Lighting, which consists of lampposts and lighting attached to the house; and Landscape Lighting, which consists of lighting equipment that is used to

illuminate objects (including pathways) in outdoor spaces, and Decorative Holiday Lighting, which consists of decorative lighting during a certain period for the Holiday Season.

Safety lighting

Replacement of a builder-provided fixture with the same (in terms of style, size, materials, color, and voltage) fixtures does not require an application. All other replacements and additional fixtures do require an application.

Replacements and additional fixtures shall be compatible in style, scale, color, and materials with the house. With the exception of movement sensitive lights, fixtures on the main entrance side of the house shall be decorative, not utilitarian type. Wires and conduit shall not be visible.

Movement sensitive lights shall be adjusted so as not to turn on when there is movement outside of property boundaries or on the sidewalk. Other exterior lights (including floodlights) shall be adjusted downwards so as not to shine outside of property boundaries or cause glare. Floodlights shall be no more than 150 watts, total (75 watts per lamp for double lamp floodlights). Size of lot, size of house relative to lot, and proximity to neighbors will all be considered in determining total wattage allowed on all sides of house. The homeowner's need for security shall be balanced with the neighbor's need for privacy. Light bulb colors shall be limited to colorless and yellow except during the winter holiday season (see Decorative Holiday Lighting).

Decorative lighting (single family, townhouse, and manor home)

The Design Review objective when reviewing landscape and path lighting is a subtle, natural effect.

- Locations for lights should be chosen so that the light is seen and not the lamp. This may be done by partially or fully hiding the lamp behind or among plantings.
- Use different lighting techniques, such as up lighting, (to accent a special plant), and down lighting (to light an object) for different areas but try to match the styles of the fixtures.

Only lighting fixtures rated as low voltage (12 volts) and no more than 7 watts shall be used, and no wires or conduit shall be visible. Alternate the placement of path lights from side to side to avoid the appearance of runway lights. Light bulbs shall be clear or white except during the winter holiday season (November 1 through January 15th). Path lighting shall be placed no closer than 5 feet apart and be as unobtrusive as possible (refer to path lighting diagram).

Landscape lighting

Only lighting fixtures rated as low voltage (12 volts) and no more than 7 watts shall be used, and no wires or conduit shall be visible. Alternate the placement of path lights from side to side to avoid the appearance of runway lights. Light bulbs shall be clear or white except during the winter holiday season (November 1st through January 15th.)

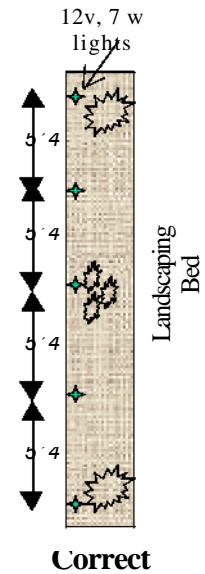
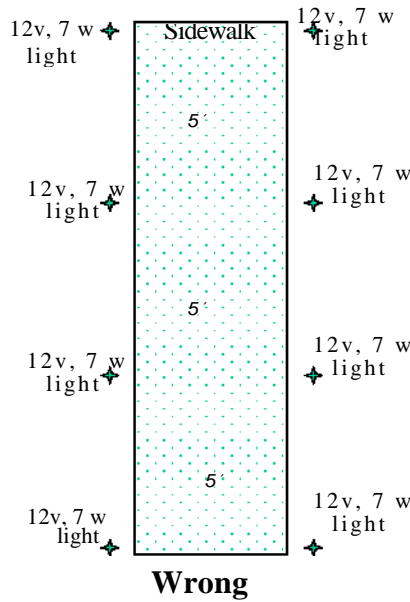
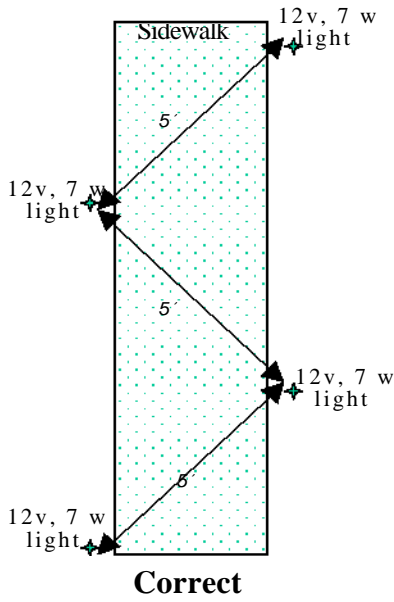

Converting wattage to Lumens

Though some LED and CFL bulbs are listed with their wattage equivalent, it is important to know how to convert the wattage your incandescent bulbs use to lumens and the wattage your new bulbs will require. Here is a table to help you find the corresponding lumens and wattage to your old incandescent bulbs.

Incandescent/Halogen Wattage	Lumens	LED or CFL wattage
25	250	4-9
40	450	9-13
60	800	13-15
75	1110	18-25
100	1600	23-30
125	2000	22-40
150	2600	40-45

Holiday decorations and lighting

Holiday decorations and lighting shall not require approval if installed between November 1st and removed by January 15th. This is to include any holiday lighting and decorations that are attached and/or unattached to the home and/or property.

All other holiday decorations (e.g., Easter, Halloween) and lighting that are attached and/or unattached to the home and/or property shall not require approval if placed on property thirty (30) days prior to the holiday and removed thirty (30) days after the holiday.

Application Contents - listed on Lighting Application Checklist in Appendix B, color photo of affected area

34. Open Porches (single family)

Location and Size

Open porches may be located on any side of the house where there is a door. Size shall be in proportion to the size of the house and lot. Open porches off of the upper (bedroom) level of the house will be considered on a case-by-case basis, and only when they do not infringe on neighbors' privacy.

Design

Design of the porch (including trim detail and roof style) shall be architecturally compatible with the design of the house. With the exception of flat-roofed portico porches adorned with railings, minimum roof slope shall be 3' in height for each 12' in length. Open porches with knee walls shall follow the guidelines for Screened Porches.

Materials

Roof shingles shall match those on the house, with the exception of those houses in Belmont and Morven where the builder had an option of a tin roof on the front porch. Similar houses in those neighborhoods may add open porches with tin roofs. The color of a tin roof shall coordinate with colors of the house. All visible members shall be pressure treated or other naturally weather-resistant wood or composite material. Flooring may be pressure treated or naturally weather-resistant wood, or composite material.

Color

Front and side porches shall be painted to match trim on the house. Rear porches may be painted to match neutral-colored (shades of white, beige, or gray) house trim or siding. Flooring color may differ from the trim of the house and will be considered on a case-by-case basis. Wood may also be stained a wood-tone stain or to match stained house siding (e.g., Suncatchers). Color of the roof shall be the same as the house roof.

Application Contents- site plat (addition), color photo of affected area, dimensions, elevation, materials, color, and style of house

35. Open Porches (townhouse and manor home)

Location and Size

Open porches shall be attached to the rear of the house at ground level. Side yard open porches on end *units* shall be considered based on visibility and impact on neighbors. Location shall not impair the views or the amount of sunlight and natural ventilation reaching adjacent properties. Size shall be in proportion to the size of the house.

Design

Design of the porch (including trim detail and roof style) shall be architecturally compatible with the design of the townhouse. Roof shall be shed style. Minimum roof slope shall be 3' in height for each 12' in length. Open porches with knee walls shall follow the guidelines for Screened Porches. If railing is used, it shall match any deck railing. If there is no deck, follow deck-railing guidelines.

Materials

Roof shingles shall match those on the house. Knee walls shall be of the same material (in composition and style) as the walls to which they are attached. The gable or upper end under a shed style roof shall be siding to match the house; natural wood siding (not plywood) to match the porch frame; or T-111 pressure-treated wood. The frame shall be pressure treated or naturally weather-resistant wood.

Wood may be left to weather naturally or a wood-tone stain may be applied to the porch of any house. Stain color shall match that of the deck if there is one. Siding and roof shingles shall be the same as the siding and roof shingles, respectively, of the house.

Application Contents- site plat (addition), color photo of affected area, dimensions, elevation, materials, color, and style of house.

36. Patios and ground level decks (single family, townhouse, and manor home)

Patios and ground level decks (no higher than 18 inches above grade) provide a means for ground level extensions of outdoor space with less visual impact than elevated decks. When patios and ground level decks include other exterior changes, such as fencing, elevated deck, lights, plantings, etc. other appropriate sections of these guidelines should be consulted, as required, prior to application.

Location

Except in unusual circumstances, patios and ground level decks shall be placed in rear yards. Side yard patios will be considered on a case-by-case basis. Front yard patios and ground level decks are not permitted.

Privacy of adjacent homes shall be considered when planning patios and ground level decks. In reviewing applications for patios and ground level decks for homes on Cul-de-sacs, pipe stems, and other small or unusually situated lots, very serious consideration shall be given to the balance between one homeowner's right to privacy and the adjacent homeowner's right to enjoy his or her yard.

Design

The design shall be compatible with the house design, lot configuration, and size of yard. Ground level decks without railings may extend to the rear property line. Ground level decks with railings shall extend no farther back than $\frac{1}{2}$ of the rear yard. Ground level decks extending to the rear property line may have planters no higher than 24 inches at the rear end.

Lattice and Privacy Screens

- Privacy screens shall be no higher than 6 feet above deck level, whether lattice or other type. With the exception of hot tub enclosures, patios and ground level decks shall not be entirely enclosed with privacy screening.
- Any lattice used above deck or patio level shall be framed along all edges (including where two pieces are connected) on the outward-facing side.

Overhead Trellis

- An overhead trellis is an open, wooden structure designed to provide screening from the sun.
- The overhead structure shall consist of lathing (wooden slats) or framed lattice.
- The trellis shall be compatible with the house and patio or deck in terms of scale and architectural style.
- The trellis shall match a ground level deck in material and color.
- Trellis shall not begin or end anywhere within the area occupied by a window or door.
- Overhead trellis shall not be covered with non-plant material.

On-Deck and Patio Lighting

- Low voltage lighting (12 volts) shall be used.
- All lighting shall be non-invasive.
- Soft and subtle lighting is encouraged.

Materials and Color

Wood shall be pressure-treated or naturally weather resistant (e.g., redwood or cedar). Stains of natural wood colors are acceptable. For single family homes, paints matching a neutral (shades of white, beige, or gray) trim or dominant color of the house are acceptable but will be considered on a case-by-case basis. Wood left to weather naturally is always an acceptable option. Patio materials shall be compatible with existing materials on the house.

Drainage

If changes in grade or other conditions which will affect drainage are anticipated, they must be indicated on the application. All drainage problems, whether anticipated or not, shall be corrected by the homeowner responsible for the problem.

Modifications of Existing Patios and Ground Level Decks

The above sections on Design, Location, Materials and Color, and Drainage apply also to all modifications. In addition, all modifications shall match the existing patio or ground level deck in all detailing such as materials and color.

Application Contents - site plat (addition), color photo of affected area, checklist (see Appendix B) dimensions, materials, color. Provide elevation if benches, planters, etc. are included.

37. Play equipment (single family, townhouse, and manor home)

Play equipment and its relationship to the house has an aesthetic impact on neighbors. Inappropriately designed or unsuitably located play equipment can have a negative visual and functional impact on an otherwise desirable residential area. The focus of these guidelines is to reconcile the need for play equipment with the goal of minimizing its visual impact.

The following guidelines regarding location, size, maintenance, and removal apply to all play equipment, whether temporary or permanent. Temporary play equipment, (e.g., plastic playhouse and soccer goals) are defined as that play equipment that is moveable and intended to be used in its location for a limited time, although some disassembly may be required to move the equipment. Permanent play equipment (e.g., wooden playhouse or other wooden structure) is defined as that equipment which is not intended to be used in its location for a limited time; it is not intended to be disassembled and moved.

Location and Size - All Play Equipment

Play equipment shall be placed in rear yards. Side yard locations will be considered based on visibility and impact on neighbors. Size shall be compatible with lot size and with location on the property. Play equipment is not permitted on common area except during temporary play, such as a game of volleyball or croquet.

Maintenance and Removal - All Play Equipment

Play equipment shall be removed when it no longer serves its intended recreational purpose (e.g., when the children have outgrown it). Additionally, play equipment shall be removed when it becomes an aesthetic nuisance because of deterioration or improper maintenance (e.g., rust, denting, peeling paint).

Swing Sets

Swing sets that are permanently attached to the ground (e.g., with concrete footings) require application. It is recommended that such swing sets be constructed of pressure-treated, weather resistant wood which is allowed to weather naturally. Wood-tone stains will be considered. Permanent metal swing sets are permitted; however, they shall be maintained so as to be rust-free, properly painted or galvanized, and without significant dents. Under no

circumstances shall the height of a swing set exceed 13 feet, at its highest point. However, each application will be reviewed on a case-by-case basis.

Tree Houses and Play Towers

Tree houses and play towers require application. They shall be open type (i.e., one can see through them as with deck railing) structures in order to be visually unobtrusive. Enclosed play towers and tree houses are prohibited. Roof to floor spindles or deck-type railings with spindles and posts can be used to provide safety. Lattice enclosures shall not be permitted. Structures shall be pressure-treated wood left to weather naturally or stained with a wood-tone stain. If roofed, the roof cover shall match that of the primary structure or, if the tree house or play tower is placed next to trees, the roof may be covered with cedar shakes. Colored canvas sun shields, as provided with commercial gym sets and play structure kits are also acceptable. The height of a play tower shall not exceed 13 feet.

Playhouses

All playhouses, other than small, temporary plastic playhouses, will require an application and will be reviewed on a case-by-case basis.

Sandboxes

All sandboxes, other than small, temporary plastic sandboxes, will require an application and will be reviewed on a case-by-case basis.

Basketball Equipment

Portable basketball goals are strongly encouraged and do not require application. Permanent basketball goals do require application. Permanent basketball goals may be attached to the front of a garage faced with brick or wood siding. In the rear of the house, a basketball goal may also be attached to the side of a deck. Permanent, freestanding basketball goals are generally permitted. However, lot size and potential negative impact on neighbors shall be taken into consideration in the placement of all permanent basketball goals. Neighborhoods may adopt guidelines on location of permanent, freestanding basketball goals that supersede these location guidelines.

Backboards shall be white, clear, or painted to match the surface to which they are attached. The backboard must be free of all advertising and logos, but may have a contrasting color, rectangular outline designating the center point of goal. Poles shall be painted dark brown, dark green, or black to blend with the natural surroundings; or gray or white to blend with the house, whichever is least conspicuous.

Application Contents - site plat (other), color photo of affected area, dimensions, elevation, materials, color

38. Propane tanks (single family, townhouse, and manor home)

Propane tanks shall be no larger than the 100-gallon size, which are typically 5 feet in height. The tank shall be located on the side or rear of the house (rear only for townhouses) and shall be screened by landscaping or other aesthetically suitable material.

The homeowner shall obtain a Loudoun County permit for installation of the tank and shall file a copy of the inspection with the Proprietary within 30 days of inspection by the county.

Application Contents - site plat (other), color photo of affected area, dimensions, elevation.
Include description of landscaping that will be used to screen tank.

39. Radon remediators (single family, townhouse, and manor home)

Radon remediators are to be located at the rear of the house unless another location is necessary to reduce radon levels. If a location other than the rear of the home is proposed, supporting documentation shall be required. In such cases landscape screening shall be added. The Design Review Coordinator can consider such an application as “standard”.

Application Contents - site plat (other), color photo of affected area, dimensions, elevation, and color.

40. Railings and ramps (single family, townhouse, and manor home)

Railings

Railings may be added to front porches or steps and shall be architecturally compatible with the design of the house. If railings are added to a porch with existing railings, they must match in color and style to the existing porch railings.

Materials and Color

Materials must match materials of any existing porch railings. If a new railing is to be installed, acceptable materials are wood, metal, or plastic composite. Any new railings must be compatible with color scheme of house.

Ramps

Ramps installed for Handicap access shall be compatible with the architectural design of the house and may be installed at any entrance to the house. Dimensions shall follow the Guidelines suggested by the Americans with Disabilities Act (ADA). See ADA accessibility Guidelines; Section 4.0 for Ramps. This information can be accessed at www.ada.gov.

Materials and Color

Materials and color shall be compatible with design of the house and harmonious with the neighborhood. Materials may be pressure treated wood or composite.

Application Contents- site plat, dimensions, drawing, materials, color, style of house and a photo of proposed railing or ramp location, color photo of affected area.

41. Rain barrels (single family, manor homes and townhomes)

Rain barrels require an application and must be located in rear yards at ground level. All other locations will be considered on a case- by -case basis and will be subject to formal review.

Rain barrels shall be less than 60 gallons, and must blend in with the surroundings, and be screened. Rain barrels must be a solid color, must have a sealed lid, and must be placed under a down spout. The Design Review Coordinator can consider this a standard application.

Application Contents -Site plat, dimensions, color photo of affected area, brochure, description of product, color, and style of house.

42. Roof shingles (single family and manor home)

Replacement shingles shall be of the same or similar color and style as on the existing roof or as on comparable roofs in the immediate neighborhood and do not require an application. If a color change is proposed, it shall be compatible with the siding and trim and an application is required. For manor homes, the color and style shall be the same on both sides of the building.

Application Contents - materials, color, and style of house, color photo of affected area

43. Roof shingles (townhouse)

Replacement shingles for townhouses require an application. If the proposed roof replacement meets the “Standards” listed below, the DRC Coordinator can consider it a standard application and approve it.

Globe Colonial Townhomes- Foxfield & Welbourne

Color changes for the entire roof are permitted. Such changes shall be architecturally harmonious with the colors of the siding, trim, shutters, and door and with other roof colors in the neighborhood. Architectural/Textured/Hail Resistant roof shingles are permitted.

Globe Colonial Townhomes- Oakridge

The approved standard replacement shingle for Oakridge Globe Colonial townhomes shall match in both color and style to “CertainTeed Landmark”, the color is “Burnt Sienna” **OR** Owens Corning, style TruDefinition Duration, the color is “Brownwood”. **Color changes are not permitted.** Architectural/Textured/Hail Resistant roof shingles are permitted. The standard for Oakridge Globe Colonial Townhomes is:

COURT	NUMBER	COLOR
Felsted Court	ALL townhomes	“Burnt Sienna” or “Brownwood”
Finchingfield Court	ALL townhomes	“Burnt Sienna” or “Brownwood”
Sulgrave Court	ALL townhomes	“Burnt Sienna” or “Brownwood”
Waltham Court	ALL townhomes	“Burnt Sienna” or “Brownwood”

Tudor Townhomes - Morven and Oakridge

The approved standard replacement shingle for Morven and Oakridge Tudor Style townhomes shall match in both color and style to “CertainTeed Landmark”, the color is “Burnt Sienna” **OR** Owens Corning, style TruDefinition Duration, the color is “Brownwood”. **Color changes are not permitted.** Architectural/Textured/Hail Resistant roof shingles are permitted. The standard for Oakridge Globe Colonial Townhomes is:

COURT	NUMBER	COLOR
Chelmsford Court	ALL townhomes	“Burn Sienna” or “Brownwood”
Lyndhurst Court	ALL townhomes	“Burnt Sienna” or “Brownwood”
Millard Court	ALL townhomes	“Burnt Sienna” or “Brownwood”

Scarborough Townhomes- Morven

The approved standard replacement shingle for Morven Scarborough townhomes shall match in both color and style to the “CertainTeed XT-25, CertainTeed Landmark, Owens Corning or IKO Dynasty colors listed below. **Color changes are not permitted.** Architectural/Textured/Hail Resistant roof shingles are permitted. The standard for Morven Scarborough townhomes is:

COURT	NUMBER	COLOR
Aldridge Court	#1-11–odd numbers only	“Slate Gray” or “Colonial Slate”
Aldridge Court	#13-23-odd numbers only	“Moire Black “or Granite Black”
Aldridge Court	#25-35-odd numbers only	“Slate Gray” or “Colonial Slate”
Aldridge Court	#2-8-even numbers only	“Burnt Sienna” or “Brownwood”
Aldridge Court	#10-20-even numbers only	“Slate Gray” or “Colonial Slate”
Aldridge Court	#22-34-even numbers only	“Cedar Brown” or “Brownwood”
Aldridge Court	#36-46-even numbers only	“Burnt Sienna” or “Brownwood”
Aldridge Court	#48-54-even numbers only	“Moire Black “or Granite Black”
Haxall Court	#1-13-odd numbers only	“Moire Black “or Granite Black”
Haxall Court	#15-23-odd numbers only	“Moire Black” or “Granite Black”
Haxall Court	#25-39-odd numbers only	“Slate Gray” or “Colonial Slate”
Haxall Court	#2-10-even numbers only	“Burnt Sienna” or “Brownwood”
Haxall Court	#12-26 even numbers only	“Burnt Sienna” or “Brownwood”
Haxall Court	#28-42 –even numbers only	“Burnt Sienna” or “Brownwood”
Ludwell Court	#1-13-odd numbers only	“Burnt Sienna” or “Brownwood”
Ludwell Court	#15-25- odd numbers only	“Slate Gray” or “Colonial Slate”
Paxton Court	#2-16-even numbers only	“Slate Gray” or “Colonial Slate”
Paxton Court	#18-28 –even numbers only	“Burnt Sienna” or “Brownwood”
Paxton Court	#30-42-even numbers only	“Slate Gray” or “Colonial Slate”

Scarborough Townhomes- Welbourne

If the color and style remain the same as existing it can be considered a “standard” application, Color changes are subject to the formal committee review process.

The approved standard replacement shingle for Welbourne Scarborough townhomes shall match in both color and style to the “CertainTeed XT-25, CertainTeed Landmark, Owens Corning or IKO Dynasty colors listed below. **Color changes are not permitted.** Architectural/Textured/Hail Resistant roof shingles are permitted. The standard for Welbourne Scarborough townhomes is:

COURT	NUMBER	COLOR
Berkeley Court	2-30 even numbers only	"Colonial Slate"
Berkeley Court	1-31 odd numbers only	"Colonial Slate"
Berkeley Court	33-47 odd numbers only	"Burnt Sienna" or "Brownwood"
Conoy Court	2-14 even numbers only	"Burnt Sienna" or "Brownwood"
Conoy Court	1-11 odd numbers only	"Moire Black" or "Granite Black"
Hopton Court	2-24 even numbers only	"Colonial Slate"
Jermyn Court	1-9 odd numbers only	"Moire Black" or "Granite Black"
Jermyn Court	11-23 odd numbers only	"Burnt Sienna" or "Brownwood"
Nicholson Court	1-9 odd numbers only	"Burnt Sienna" or "Brownwood"
Nicholson Court	11-31 odd numbers only	"Moire Black" or "Granite Black"
Nicholson Court	33- odd number only	"Moire Black" or "Granite Black"
Nicholson Court	2-10 even numbers only	"Colonial Slate"
Nicholson Court	12-32 even numbers only	"Burnt Sienna" or "Brownwood"
Vandercastle Road	1-11 odd numbers only	"Colonial Slate"
Vandercastle Road	13-21 odd numbers only	"Colonial Slate"

Application Contents - materials, color, style of house and roof shingle sample. Applications **must** state that the color of the replacement shingle matches the approved roof color. Roof color samples for the "Standards" listed above are available for viewing at the Proprietary office.

44. Room additions/house expansion (single family)

The addition of a room or sunroom, or any expansion of the house (hereinafter referred to as "addition"), will have a significant visual and physical impact on the appearance of the house. Such an addition may also affect the privacy of adjacent properties. These two factors will be weighted heavily in the review of applications. Equal consideration shall be given to the rights of both homeowners to live comfortably and with adequate privacy.

Location

Additions shall be located on the rear or side of the home and shall be considered on a case-by-case basis. The addition shall not impair the view, sun, or ventilation of any neighbor.

Design

The design objective in reviewing additions shall be a "seamless" appearance, i.e., the addition shall appear to be part of the original house, not a box that has been stuck onto it. This is achieved, in part, by matching the new roof style to

that of the existing roof or adding a new roof that is not incompatible with the existing roof. There are three roof styles in CountrySide.

HIP
(Front View)

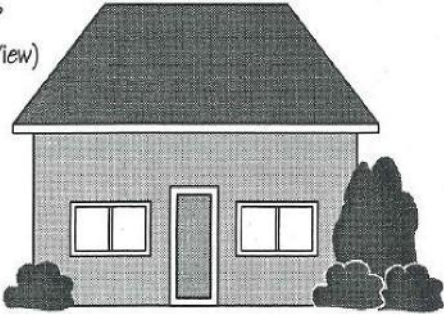

GABLE
(Side View)

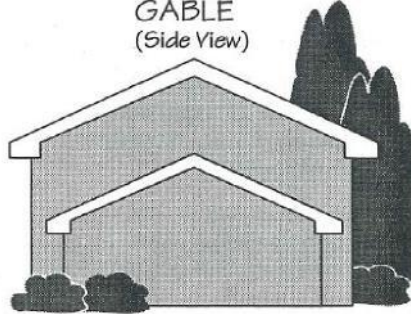

In most cases, the roof on an addition should be the same style as on the original structure. However, there may be instances in which a mixture of styles would be appropriate. The final appearance shall be a harmonious blend of rooflines. Slope of the new roof shall, to the extent possible, match that of the existing roof (with the minimum being 3/12).

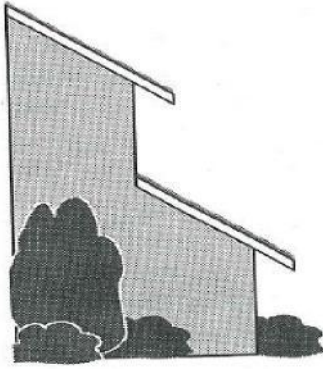

SHED
(Side View)

The style of new doors and windows shall match the style of existing doors and windows. Please see the two separate sections **DOORS** and **WINDOWS** for more detailed guidance.

The placement of new walls, windows, doors, and roofline shall relate well to the existing walls, windows, doors, and roofline. The objective here is for the entire, completed structure to present a balanced appearance.

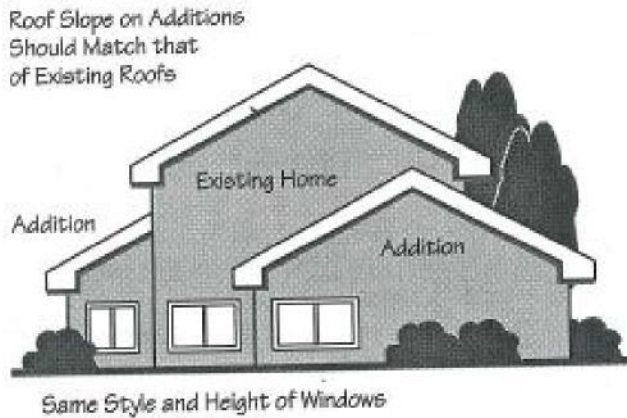

Size

Addition shall be compatible with the size of the primary structure and lot. Merely meeting County Code setback requirements is an insufficient size/location measure. The addition shall not be as massive and close to the property line as to visually impose upon an adjacent property. This is an especially important concept where houses with the main living area in the rear are situated back-to-back. Screening and landscaping can lessen the impact of an addition on neighboring properties.

Materials and Color

In most cases the composition, colors, materials, and Roof shingles shall match the existing structure. There may be instances in which a mixture of color and materials may be appropriate and shall be considered on a case-by-case basis.

Application Contents - listed *Enclosed Structure Application Checklist* in Appendix B, color photo of affected area

The Applicant should contact Loudoun County before beginning any work to verify what additional approvals or permits are required.

45. Room additions/house expansion (townhouse)

Location

Additions are restricted to the rear on the ground level and shall be set back a minimum of 1 foot from side property lines. Length of the addition shall not exceed 12 feet from the rear wall of the primary structure.

Design

Design shall be architecturally harmonious with the primary structure. Roof style is limited to shed style with a minimum slope of 3/12.

The style of new doors and windows shall match the style of existing doors and windows. Please see the two separate sections **DOORS** and **WINDOWS** for more detailed guidance.

The placement of new walls, windows, doors, and roofline shall relate well to the existing walls, windows, doors, and roofline. The objective here is for the entire completed structure to present a balanced appearance.

Materials and Color

In most cases the composition, colors, materials, and Roof shingles shall match the existing structure. There may be instances in which a mixture of color and material may be appropriate and shall be considered on a case-by-case basis.

Application Contents - listed on *Enclosed Structure Application Checklist* in Appendix B.

The Applicant should contact Loudoun County before beginning any work to verify what additional approvals or permits are required.

46. Room additions/house expansion (manor homes)

Manor homes are designed as a balanced whole. Therefore, additions to manor homes are **not** permitted.

47. Screened porches (single family)

A screened porch is an addition that is either partially or fully enclosed by screens. It does not have windows. It has a roof which may or may not have skylights.

Location and Size

Location shall not impair the views or the amount of sunlight and natural ventilation reaching adjacent properties. Screened porch shall be attached to the rear of the house, although a side location will be considered in the case of unusual house sitting or where a side location has minimal visual impact from the street or on the immediate neighbors. Screened porches off the upper (bedroom) level of the house will be considered on a case-by-case basis, and only when they do not infringe on neighbors' privacy. In considering an application for an upper-level screened porch, balance and harmony with the primary structure is considered. Size of all screened porches shall be in proportion to the lot and house size.

Design

Roof style shall be gable end or shed if house is gable end. Any roof style is acceptable on a house with a hip roof, although a hip style porch roof is preferable if the house and garage roofs are both hip style and no gables exist anywhere on the structure. To the extent possible, the slope of the roof should match the slope of the house roof. However, the minimum slope allowed shall be 3' in height for 12' in length.

Railing shall match deck railing. If there is no deck, follow deck railing guidelines. Screen doors and trim detail shall be compatible with the architectural design of the house. (For example, Victorian gingerbread style house.) Placement of Gutters and Downspouts will be considered on a case-by-case basis.

Materials and Color

Roof shingles shall match those on the house. Screens shall match existing screens. Knee walls shall be of the same material (in composition and style) as the house walls to which they are attached. The gable or upper end under a shed style roof shall be screen; siding to match the house; natural wood siding (not plywood) to match the porch frame; or T-111 pressure treated wood. The frame shall be pressure treated or naturally weather-resistant wood. Screen doors shall be wood-framed or aluminum, matching the color of the porch framing. Winterizing screens with plastic or Plexiglass is prohibited.

Wood may be left to weather naturally or may be painted or vinyl wrapped to match neutral-colored (shades of white, beige, or gray) house trim or siding. Wood may also be stained to match stained house siding (i.e., Suncatchers). A wood-tone stain may be applied to the screened porch of any house if the deck is stained. Stain color shall match that of the deck. Color of the screens, siding, and roof shingles shall be the same as the screens, siding, and roof shingles, respectively, of the house.

Application Contents- Listed on *Enclosed Structure Application Checklist* in Appendix B, color photo of affected area

48. Screened porches (townhouse and manor home)

Location and Size

Location is restricted to the rear and only on ground level decks or as a screened enclosure below a middle level deck on a townhouse. Location shall not impair the views or the amount of sunlight and natural ventilation reaching adjacent properties. Sides shall be set back a minimum of 1 foot from the property line. Rear wall of the screened porch shall extend no further than 12 feet from the rear wall of the house. Side fences shall be extended if necessary to prevent screened porch from protruding beyond the fence.

Design

Roof shall be shed style. To the extent possible, the slope of the roof should match the slope of the townhouse roof. However, the minimum slope allowed shall be 3' in height for 12' in length. Railing shall match deck railing. If there is no deck, follow deck railing guidelines. Screen doors and trim detail shall be compatible with the architectural design of the house. (For example, Victorian gingerbread trim is not appropriate on either a Tudor or Colonial style house.) Placement of gutters and downspouts will be considered on a case- by- case basis.

Materials

Roof shingles shall match those on the house. Screens shall match existing screens. Knee walls shall be of the same material (in composition and style) as the walls to which they are attached. The gable or upper end under a shed style roof shall be screen; siding to match the house; natural wood siding (not plywood) to match the porch frame; or T111 pressure-treated wood. The frame shall be pressure treated or naturally weather-resistant wood. Screen doors shall be wood-framed. Winterizing screens with plastic or Plexiglass are prohibited.

Wood may be left to weather naturally or a wood-tone stain may be applied to the screened porch of any townhouse if the deck is stained. Stain color shall match that of the deck. Color of screens, siding, and roof shingles shall be the same as the screens, siding, and roof shingles, respectively, of the townhouse.

Application Contents - listed on *Enclosed Structure Application Checklist* in Appendix B, color photo of affected area.

49. Sheds (single family)

Storage sheds serve to conceal cluttering objects such as garden tools, trash cans, bicycles, etc., and can become necessary particularly where garage space is not available. However, if not well-planned and maintained, sheds become neighborhood eyesores. Only one shed shall be permitted per lot.

Location:

The shed location will only be approved if one of the following conditions is met:

- The shed is built as an addition to the primary structure, attached to the rear of the house. Addition to the side of the house will be considered on a case-by-case basis.
- The shed is built below an elevated deck.
- The shed is built as an attachment to the inside of approved **privacy** fencing. If this is done, the shed must not be visible above the fencing.

Free-standing sheds will be considered on a case-by-case basis and shall meet the following conditions:

- The shed is behind the house, not readily noticeable from the street,
- The shed shall be designed and placed to respect the visual right of neighboring properties. If shrubs or bushes are used as screening and/or to improve the visual impact, these shall be at least four feet high at planting, must be maintained at a minimum of 4 feet and must be kept alive.

Design and Maintenance:

The architectural design of the shed shall be compatible with the design of the house, and, as such, shall maintain a continuity of building lines, materials, color, and size with the house. Minimum roof slope is 3'rise/12' length. The appearance of the shed shall be maintained to the same standards as homes in CountrySide, as specified in the Architectural Guidelines, i.e., properly painted, no rusted hardware, broken windows, structure, and shingles in good repair.

Materials and Color:

The finish materials used for the shed shall be similar or the same as the existing exterior finish materials on the house. A free-standing shed may use wood sides if the color matches that of the house siding. Because sheds attached to the house are considered extensions, materials used for sheds attached to the house or directly adjacent to the house shall exactly match that of the house in style, material, and color. In all cases roof shingles shall closely match that of the house. Metal and pressed/particle board sheds are prohibited.

Poly-resin, PVC, or sheds from similar material will be permitted only if they are under an approved deck or inside approved **privacy** fencing.

Size:

The size of the shed shall be appropriate for both the size of the house and that of the property. The height of the shed side walls shall not exceed eight feet. The foundation/footprint shall be no larger than eight feet wide by twelve feet long.

50. Sheds (townhouse)

Shed shall be attached to the primary structure or to a solid privacy fence or be located immediately next to the privacy fence. Shed shall be located in rear yards only. Poly-resin sheds will be permitted only if they are under an existing approved elevated deck and/or inside of approved privacy fencing and are not visible above the fencing. Only one shed shall be permitted.

Design

If attached to the house, the architectural design of the shed shall be compatible with the design of the house and shall be compatible with the design of the house and, as such, shall maintain a continuity of building lines, materials, color, etc., with the primary structure. If attached or placed next to the fence, the shed shall be a simple, unornamented design.

Materials and Color

Materials and color shall match the house or fence to which the shed is physically attached or most visually related. This includes matching major materials and their colors, such as on siding, trim, and roofing. **Color of polyresin sheds shall be reviewed on a case-by-case basis.**

Roof

The slope of the roof shall be consistent with that of sheds on similar or neighboring townhouses. The roof slope and the type and color of the roofing material (shingles) shall match those of the house, if not built below an elevated deck.

Size

The size of the shed (height, width, and length) shall be consistent with that of sheds on similar or neighboring townhouses. However, sheds shall not exceed the following dimensions 8'H x 4'W x 8'D.

Application Contents -shed checklist (see Appendix B), site plat (addition), color photo of affected area, dimensions, elevation, materials, color, and style of house.

51. Sheds (manor home)

Location

Sheds shall be attached to the primary structure in the rear or if house entrance is on the front, may be attached to the side rear. Sheds may also be attached or placed immediately next to a solid privacy fence. Only one shed shall be permitted.

Design

If attached to the house, the architectural design of the shed shall be compatible with the design of the house and, as such, shall maintain a continuity of building lines, materials, colors, etc., with the primary structure. If attached or placed next to the fence, the shed shall be a simple, unornamented design.

Roof

The slope of the roof shall be consistent with the roof slope of the primary structure or with that of sheds on other manor homes. Minimum roof slope is 3/12. The size of the shed (height, width, and length) shall be appropriate for the size of the lot and the house.

Materials and Color

Materials and color shall match the house or fence to which the shed is physically attached or most visually related. This includes matching major materials and their colors, such as on siding, trim, and roofing.

Application Contents -shed checklist (see Appendix B), site plat (addition), color photo of affected area, dimensions, elevation, materials, color, and style of house

52. Shutters (single family, townhouse, and manor home)

Shutters which are added to the house shall match, in style and color, any existing shutters and shall be compatible with the style of the house. Shutters shall be of proper proportions to match the windows to which they relate. Color of additional shutters shall match that of existing shutters and change of shutter color shall be compatible with the colors of the house and neighborhood. (See also, **COLOR CHANGES**.) Changes in style of shutters shall be compatible with the architectural style of the house. *The removal of shutters from the house requires an application.*

Application Contents - site plat (other) for shutters to be added to windows that did not previously have them, color photo of affected area, dimensions, elevations, materials, color, and style of house for all shutter additions or changes.

53. Siding (single family & manor homes)

Siding replacement, **changes and/or alterations** requires **an** application, as stated in Administrative Resolution # 183. ***Siding may be either vinyl, aluminum, or fiber cement board. All siding changes, including color, shall require an application. If color and style remain exactly the same, and the material is changed to aluminum, vinyl, or fiber cement board, the Design Review Coordinator may consider this a standard application and approve the application. In addition, a change in style between Dutchlap and Clapboard may be approved as "standard". Repair to siding and replacement of missing siding shall be of the exact material and color as rest of dwelling.***

Application contents: materials, color, style of house, samples of product, color photo of affected area, *Color Change Application* checklist in Appendix B.

Siding (townhouse)

Throughout Countryside many of the townhomes have standard and approved colors for siding. These standard colors are listed below.

Globe Colonials (Foxfield, Oakridge & Welbourne)

All siding replacement shall require an application as stated above, color and style shall remain the same or **changed to** an approved Proprietary Color. Siding shall be the exact color and material on all sides of the dwelling. Adjacent dwellings may not have the same siding color.

Repair to siding shall be the exact material and color as rest of dwelling. Oakridge pre-approved siding colors and manufacturer information are available at the Proprietary office. ***The standard for Oakridge Globe Colonials is as follows:***

Felsted Court	Cypress, Oxford Blue, Snow, Sterling Grey, Wedgewood Blue by CertainTeed.
Finchingfield Court	Cypress, Desert Tan, Oxford Blue, Snow, Wedgewood Blue by CertainTeed. Greystone by Crane.
Sulgrave Court	Cypress, Desert Tan, Granite Grey, Oxford Blue, Sandstone Beige, Snow, Sterling Grey, and Wedgewood Blue by CertainTeed.
Waltham Court	Cypress, Oxford Blue, Savannah Wicker, Snow, Sterling Grey, and Wedgewood Blue by CertainTeed.

Application contents: materials, color, style of house, samples of product, color photo of affected area, *Color Change Application* checklist in Appendix B.

Scarborough (Welbourne & Morven)

All siding shall require an application as stated above. Siding color and manufacturer is available at the Proprietary Office. Siding shall be the exact color and material on all sides of the dwelling.

Repair to siding shall be the exact material and color as rest of dwelling. **The standard for Scarborough town homes is as follows:**

Aldridge Court	2 through 8 - even numbers	Monterey Sand by Alside
Aldridge Court	1 through 11- odd numbers	Sterling Grey by CertainTeed
Aldridge Court	10 through 20- even numbers	Sterling Grey by CertainTeed
Aldridge Court	13 through 23- odd numbers	Mist Blue by Revere
Aldridge Court	22 through 34 -even numbers	Vineyard Stone by Variform
Aldridge Court	25 through 35- odd numbers	Cape Cod Grey- Odyssey Plus- Alside
Aldridge Court	36 through 46- even numbers	Sand, Autumn Wood Collection by Heartland
Aldridge Court	48 through 54 -even numbers	Mist Blue by Revere
Haxall Court	1 through 13- odd numbers	Cape Cod Grey- Odyssey Plus -Alside
Haxall Court	2 through 10- even numbers	Prairie Sand by CertainTeed
Haxall Court	15 through 23-odd numbers	Oxford Blue Monogram by CertainTeed
Haxall Court	12 through 26-even numbers	Pebblestone by Alcoa
Haxall Court	25 through 39-odd numbers	Cape Cod Grey by Alside
Haxall Court	28 through 42- even numbers	Monterey Sand by Alside
Ludwell Court	1 through 13- odd numbers	Pebble Charter Oak by Alside
Ludwell Court	15 through 25- odd numbers	Sterling Grey by CertainTeed
Paxton Court	2 through 16- even numbers	Natural Clay by Alside
Paxton Court	18 through 28-even numbers	Maple by Alside
Paxton Court	30 through 42-even numbers	Slate by Owens, Grey, Autumn Wood Collection by Heartland
Conoy Court	1 through 11- odd numbers	Mist Blue by Revere
Conoy Court	2 through 14- even numbers	Maple by Alside
Jermyn Court	1 through 9- odd numbers	Cape Cod Grey by Alside
Jermyn Court	11 through 23- odd numbers	Sandstone by Alcoa
Vandercastle Road	13 through 21- odd numbers	Maple by Alside

Vandercastle Road	1 through 11- odd numbers	Vineyard Stone by Variform
Berkeley Court	2 through 18-even numbers	Maple by CertainTeed (Dutch lap Style Only)
Berkeley Court	1 through 15- odd numbers	Cape Cod Grey by Alside
Berkeley Court	20 through 30- even numbers	Cobblestone by Alcoa
Berkeley Court	33 through 47- odd numbers	Maple by CertainTeed
Berkeley Court	17 through 31- odd numbers	Mist Blue by Revere
Nicholson Court	1 through 9- odd numbers	Prairie Sand by CertainTeed
Nicholson Court	2 through 10- even numbers	Vineyard Stone by Variform
Nicholson Court	12 through 22-even numbers	Sandstone by Alcoa
Nicholson Court	24 through 32-even numbers	Cape Cod Grey by Alside
Nicholson Court	11 through 19-odd numbers	Oxford Blue by CertainTeed
Nicholson Court	21 through 31-odd numbers	Pebblestone by Alcoa
Hopton Court	2 through 10- even numbers	Maple by Alside
Hopton Court	12 through 24-even numbers	Cape Cod Grey by Alside

Application contents: materials, color, style of house, samples of product, color photo of affected area. *Color Change Application* checklist in Appendix B.

Globe Tudors (Morven & Oakridge)

Rear siding replacement shall require an application as stated above, color and style shall remain the same. Siding **shall be of the exact color and style on rear of dwelling. Changes in color are not allowed.** Repair to siding shall be the exact material and color as rest of dwelling. The standard siding for a Tudor home is Maple by CertainTeed Double 4".

Front fiber cement siding replacement shall require an application as stated above, color and style shall remain the same. **Changes in color are not allowed.** The standard fiber cement siding for a Tudor town home is CertainTeed "Stucco Vertical Siding" or James Hardie "Stucco" siding. **Repair to siding shall be the same standard product as noted above.**

This product will need to be painted; the standard color is listed below.

Quart: Statehouse Exterior flat 19500					
Custom: TUDOR STUCCO					
CCE*	COLORANT	oz.	32	96	128
C	Gold	-		2	-
L	Raw Umber	-		3	-
		-			-
		-			-

This paint is available at the McCormick Paints Leesburg, VA location.

Application contents: materials, color, style of house, samples of product, color photo of affected area, *Color Change Application* checklist in Appendix B.

54. Skylights (single family, townhouse, and manor home)

All skylights including tubular skylights require an application. If there are existing skylights, additional skylights should match them in color, style (flat or domed,), and materials (glass or plastic).

Application Contents - site plat (other), color photo of affected area, dimensions, elevation (drawing showing skylight on house not necessary), materials and color.

55. Solar panels (single family, townhouse, and manor homes)

Solar panels shall be placed to cause minimum visual impact on surrounding residences. Solar Panels placed on the rear roof are preferred, not required.

Panels should be centered laterally on the highest roof area and located near the ridge line. Panels should be far enough from the ridge line so that they do not protrude above the house outline when viewed from adjacent properties. Panels should be of the same size and shape and placed together to avoid gaps between individual panels. The collector surface shall be parallel to the roof and as close as mounting hardware permits.

All conduit, piping, and control devices must be a close or exact match to the color of the roof or the element upon which it is installed. Wire molding tracks and boxes to obscure conduit is preferred. All piping and conduit shall run with the lines of the house. Large collector Solar systems larger than the size of the Roof will be considered on a case-by-case basis.

Application Contents - site plat (other), color photo of affected area, dimensions, elevation, and color

56. Swimming pools

Only in-ground pools will be considered. **Above-ground pools are prohibited.**

Some lots in CountrySide are too small to be considered for a backyard pool. Therefore, all pool applications shall be considered on a case-by-case basis. Swimming pools shall be located to the rear of the house. County ordinance requires fencing around the pool. Please see the guidelines section on **FENCES**. Landscaping may be required to lessen the impact of the pool and fence.

Application Contents - site plat (addition), color photo of affected area, dimensions, elevation (of any above ground elements, such as benches), materials.

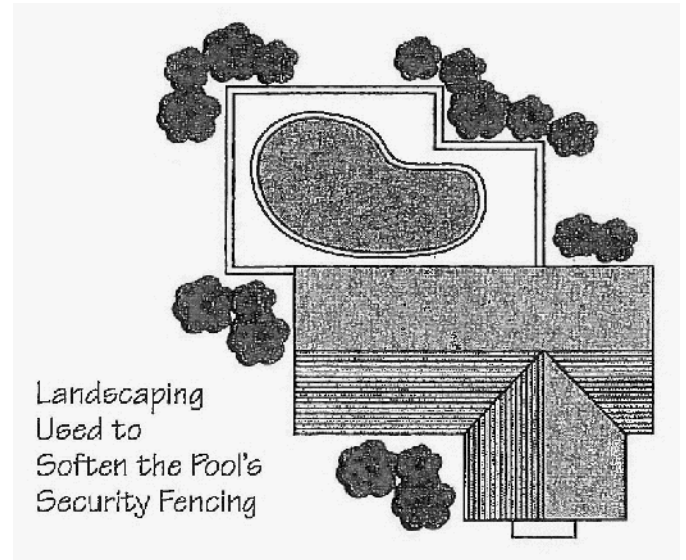

57. Temporary storage containers (pods, dumpsters, rolls offs) single family

An application must be submitted. Temporary storage containers may be placed in residential driveways only, for a period not to exceed sixty days. The Design Review Coordinator can consider such an application as "standard". Other locations may be considered on a case- by- case basis and will not be considered a "standard" application.

Application Contents - Specify approximate dates when container will be on premises, and dimensions of the container. color photo of affected area.

58. Temporary storage containers (pods, dumpsters, rolls offs) townhouse and manor homes)

An application must be submitted. Temporary storage containers shall be placed in the resident's assigned parking space(s) only for a period not to exceed sixty days. The Design Review Coordinator can consider such an application as "standard". The container must not exceed the length and width of the parking space(s).

Application contents - Specify approximate dates when container will be on premises, and dimensions of the container, . Signatures of the four most affected neighbors are required.

59. Tree removal (single family, townhouse, and manor home)

No sound trees measuring in excess of 6 inches in diameter as measured 24 inches above ground may be removed without prior approval. No flowering, broad-leaf, or evergreen trees measuring in excess of 2 inches in diameter as measured 12 inches above ground may be cut without prior approval. Removal of dead or diseased trees or trees presenting an immediate hazard do not require an application.

All tree stumps, visible from the street must be removed or ground down to below the ground level.

Application Contents- site plat (other), color photo of affected area, dimensions (approximate height and diameter as measured 24 inches above ground for hardwood trees and 12 inches above ground for flowering or broad-leaved evergreen trees).

60. Trim & trim wrap (all neighborhoods)

The following criteria shall be followed for a standard application to be approved for a material change to the exterior trim of a dwelling. An applicant wishing to deviate from the standard is encouraged to do so. However, such applications shall be subject to formal review procedures. This standard shall apply to all single family, townhouses, and manor homes. Trim shall match in color on all sides of the home.

The standard is as follows:

The replacement of all exterior wood trim with vinyl-covered aluminum wrap, fiber cement or PVC may be approved as a standard application as long as the trim matches the approved wood trim color.

Applications must state that the color of the trim or trim wrap matches the approved color of wood trim color. The application also requires a color photo or sample of the proposed trim or trim wrap. No signatures are required from neighbors for a standard application request.

Trim color for Scarborough town homes

The standard for Scarborough townhomes is as follows:

COURT	NUMBER	COLOR OF TRIM
Aldridge Court	#2 through 8-even numbers	*Rugged Canyon
Aldridge Court	#1 through 11-odd numbers	*Harbor Blue
Aldridge Court	#10 through 20-even numbers	Sugarloaf
Aldridge Court	#13 through 23-odd numbers	Sugarloaf
Aldridge Court	#22 through 34-even numbers	Sugarloaf
Aldridge Court	#25 through 35-odd numbers	Sugarloaf
Aldridge Court	#36 through 46-even numbers	Carriage Brown
Aldridge Court	#48 through 54-even numbers	Sugarloaf
Haxall Court	#1 through 13-odd numbers	Sugarloaf
Haxall Court	#2 through 10-even numbers	Fawn Brown
Haxall Court	#15 through 23-odd numbers	Sugarloaf
Haxall Court	#12 through 26-even numbers	Sugarloaf
Haxall Court	#25 through 39-odd numbers	Sugarloaf
Haxall Court	#28 through 42-even numbers	Carriage Brown
Ludwell Court	#1 through 13-odd numbers	Sugarloaf

Ludwell Court	#15 through 25-odd numbers	Sugarloaf
Paxton Court	#2 through 16-even numbers	Forest Green
Paxton Court	#18 through 28-even numbers	Fawn Brown
Paxton Court	#30 through 42-even numbers	Sugarloaf
Conoy Court	#1 through 11-odd numbers	Sugarloaf
Conoy Court	#2 through 14-even numbers	Carriage Brown
Jermyn Court	#1 through 9-odd numbers	Harbor Blue
Jermyn Court	#11 through 23-odd numbers	Carriage Brown
Vandercastel Road	#13 through 21-odd numbers	Carriage Brown
Vandercastel Road	#1 through 11-odd numbers	Sugarloaf
Berkeley Court	#2 through 18-even numbers	Carriage Brown
Berkeley Court	#1 through 15-odd numbers	Windsor Blue
Berkeley Court	#20 through 30-even numbers	Sugarloaf
Berkeley Court	#33 through 47-odd numbers	Carriage Brown
Berkeley Court	#17 through 31-odd numbers	Sugarloaf
Nicholson Court	#1 through 9-odd numbers	Carriage Brown
Nicholson Court	#2 through 10-even numbers	Sugarloaf
Nicholson Court	#12 through 22-even numbers	Carriage Brown
Nicholson Court	#24 through 32-even numbers	Windsor Blue
Nicholson Court	#21 through 31-odd numbers	Woodland Green
Nicholson Court	#11 through 19-odd numbers	Sugarloaf
Hopton Court	#2 through 10-even numbers	Carriage Brown
Hopton Court	#12 through 24-even numbers	Windsor Blue
*Paint formula available upon request		

Trim color for Tudor townhomes

The standard for Tudor townhomes is as follows:

Oakridge Tudor Townhomes

Chelmsford Court	McCormick Paints- Deep Forest Brown #224
------------------	--

MORVEN Tudor Townhomes

2, 4, 6, 8, 10 and 12 Millard Court only.	McCormick Paints- Black #200
Millard Court	McCormick Paints- Deep Forest Brown #224
Lyndhurst Court	McCormick Paints- Deep Forest Brown #224

Call the Proprietary Office for store location. Color Changes are not allowed.

61. Water features, and ponds (single family, townhouse, and manor)

Water features (including fountains) and ponds may be approved on selected home sites provided that their design and location are architecturally compatible with the home, and it is in harmony with the neighborhood. The edge of a pond or reflecting pool shall be at least three feet (3') from the property line. Ponds shall not be permitted in front of any town home.

Applications should include drawings, (including landscaping around the site) site plat, location, and description of existing or planned patios, decks, etc., grading, water depth, lighting, and any electrical devices. Please note that lighting must comply with the guidelines section on lighting.

62. Windows (single family, townhouse, and manor home) Storm and screen windows

Storm and screen windows shall be unobtrusive. The frame shall match the main window frame as closely as possible in color. For example: brown window frames require brown-framed storm or screen windows: for white or cream-colored window frames, white-framed storm or screen windows are acceptable. Unpainted aluminum frames are not acceptable. Replacement storm and screen windows shall match existing storm and screen windows exactly in color and style. **Materials may be changed to metal or vinyl.**

Application Contents- windows checklist (see Appendix B) and include product, color photo of affected area information.

Security bars on windows

Location

Security windows with bars shall be located on side or rear basement windows only, never on front windows, and shall not be visible from the street.

Design

Design shall be compatible with the design of the house. Design shall consist of primarily straight vertical or horizontal members, without ornamentation or scrollwork.

Color

Security windows (including bars) shall be as unobtrusive as possible in color.

Application Contents- windows checklist (see Appendix B) and product, color photo of affected area

Replacement windows (single family & manor homes)

Design

Replacement windows shall match the style of the existing windows (*i.e., double-hung, casement, slide, etc.*) **and can be either with or without muntin's or grids as long as it maintains the architectural integrity of the house.** Where a design change is requested, e.g., to install a larger window for a view, windows with no grids or to replace a double window with a bay window, the style shall be compatible with the existing windows; design shall be architecturally compatible with the design of the house; and the harmony and balance of the exterior appearance of the house shall not be disturbed.

Color and Materials

Color shall match those of existing windows. *Materials may be vinyl, fiberglass, wood, or metal. If color and style remain the same, and the material is changed, the Design Review Coordinator may consider this a "standard" application and approved by the Design Review Coordinator.*

Application Contents- windows checklist (see Appendix B) and product information, color photo of affected area.

Replacement windows (townhouse)

Replacement windows for all townhomes shall be the same color and style as the existing windows and shall maintain grids.

Color and Materials

Color shall match those of existing windows. ***Materials may be vinyl, fiberglass, wood, or metal. If color and style remain the same, and the material is changed, it may be considered a "standard" application and approved by the Design Review Coordinator.***

Application Contents- windows checklist (see Appendix B) and include product information, color photo of affected area.

Additional windows (single family, townhouse, and manor home)

Design and Location

Additional windows shall be compatible with existing windows. Design shall be architecturally compatible with the design of the house, and the harmony and balance of the exterior appearance of the house shall not be disturbed. The effect of additional windows on neighbors' privacy shall be considered.

Color and Materials

Color shall match, and style shall match those of existing windows. ***Materials may be vinyl, fiberglass, wood, or metal.***

Application Contents - site plat (other), dimensions, elevation, *windows checklist (see Appendix B) and include product information, color photo of affected area*

Exterior Alterations NOT Requiring Applications

Chimney caps (single family, townhouse, and manor home)

Chimney caps shall be of rustproof material or painted flat black.

Electronic insect traps (single family, townhouse, and manor home)

Electronic insect traps shall be placed only inside or rear yards. No device shall be installed or maintained in such a way as to cause annoyance to adjacent residents from noise and may only be operated during those times when the immediate area protected by the trap is occupied by the homeowner/resident or his or her guests.

Flagpoles (single family, townhouse, and manor home)

Wall-mounted flagpoles do not require application. The standard is defined as follows: no more than four wall-mounted flag poles shall be placed on any detached home, nor more than one on any townhouse. Only one flag may be placed on each wall-mounted flagpole. The pole shall be maintained in good condition and should be inclined 30 to 60 degrees from the wall. The pole should be 5 to 7 feet long, and the flag should be 2 to 3 feet vertical and 4 to 5 feet horizontal. If the flagpole is painted, the color should be black, gray, or white. Wall-mounted flagpoles not meeting the above definition require application. Permanent and free-standing flagpoles are prohibited.

Mailboxes (single family and manor home)

Mailboxes are a functional necessity, not a decorative item. Mailboxes shall be a United States Postmaster General approved box and shall be painted one of the following McCormick exterior colors, or its equivalent: Farmhouse Red, Foxhall Green, Old Carriage Brown, Old Colonial Red, Georgetown Green, Fairfax Brown, Deep Forest Brown, or flat Black. No exterior structures or modifications shall be added to the box (e.g., building a model house around the box or a little barn). The post shall be a single piece of pressure treated wood, allowed to weather naturally.

Neighborhoods may adopt guidelines on mailbox post colors that supersede these guidelines. Size and location and style of the mailbox shall not deviate substantially from the original builder provided mailbox. Mailboxes and posts not meeting the above specifications require application. A bona fide, recognized newspaper box (e.g., Washington Post, Loudoun Times Mirror, etc.) is a functional, delivery type item and therefore, does not require an application if attached to the mailbox post. One (1) newspaper box is permitted in those areas that do not have a builder provided newspaper slot. Any other additions to the mailbox post would be considered ornamental or decorative, as opposed to functional, and requires an application for approval.

Play equipment, temporary (single family, townhouse, and manor home)

The following do not require an application:

- small, plastic, temporary type play equipment (e.g., Little Tykes Gym, wading pools)
- portable basketball goals - However, if used in front of the house, portable basketball goals should be removed when not in use and stored out of sight of the front of the house.
- Hockey and soccer goals—however, if used in front of the house, goals should be removed nightly and stored out of sight of the front of the house.
- moveable skateboard ramps -- However, they must be removed after each use and stored
- Moveable swing sets of wood or metal-- “Moveable” is defined as not being cemented into the ground. Use of cinder blocks above ground for stabilizing is not permitted.
- Sand boxes made of pressure treated wood and not exceeding 25 square feet.
- Gliders, hammocks, and patio furniture, these are restricted to porches and rear yards.

See **Play Equipment** under **Exterior Alterations Requiring Application** for guidelines on location, size, maintenance, and removal of **all** play equipment.

Satellite dishes and antennas (single family, townhouse, and manor home)

Antennas/satellite dishes should be selected and located, to the extent possible, to minimize their appearance from the street and neighboring properties. The location should take advantage of screening provided by existing structures and/or vegetation. In accordance with the Telecommunications Act of 1996 (Act), antennas and satellite dishes not larger than one meter (39”) are permitted as a matter-of-right. No application is required for the installation of an antenna or satellite dish that does not exceed one-meter (39”) and meets the following guidelines and all of the Federal Communications Commission (FCC) requirements under the Act.

The following guidelines are to assist in the placement of an antenna or satellite dish.

- All Satellite Dishes must be one meter (39”) or less in diameter.
- Based on the required positioning to receive transmissions, antennas/satellite dishes should be placed in an inconspicuous location, preferably on the rear roof. They should not be placed in areas where they would constitute a safety hazard.
- Although roof-top antennas are permitted under the Act, the use of attic antennas (installed in the attic) is encouraged.
- Per the Act, antenna/satellite dishes are limited to a maximum height of 12’ above the roof line. Masts higher than 12 feet above the roofline may be subject to local permitting requirements.
- All wiring for antennas and satellite dishes must be properly secured. In some instances, wiring may be required to be concealed.
- Satellite dish colors should remain as purchased. Preferred colors are black, gray, tan, and other neutral tones. Where other color options exist, they should complement the color of the house to which the dish is attached, e.g., roof or siding color.
- Other than the brand name, commercial advertising on the dish is prohibited.
- Landscape planting is recommended to screen a dish from view if it is placed in a visible location on the ground.
- Antennas/satellite dishes must be placed on the homeowner’s property, not in common areas.

Signs (single family, townhouse, and manor home)

Signs advertising the sale or rental of the property shall be no larger than 6 square feet in area. One sign per lot is permitted. Real estate signs must meet Loudoun County regulations with respect to content and shall be removed within 48 hours after contract acceptance. "Beware of Dog" signs shall be attached to the house or fence, be no larger than 3 by 10 inches, and are limited to one per entrance to the yard and house. No more than two (2) security signs (i.e., those which are part of a professional home security system) shall be posted on the property. The approved locations shall be by the front or rear door/stoop, in the shrubbery within twelve (12) feet of the rear door/stoop, or on one or both sides of the mailbox post for single family and manor homes. The sign(s) shall be no larger than 12" in diameter.

Sprinklers (single family, townhouse, and manor home)

Sprinklers, both-in ground and portable, shall be placed so as not to water neighboring properties or change the drainage on neighboring properties or common area.

Vegetable gardens (single family, townhouse, and manor home)

Vegetable gardens are to be located behind the front fence line of the house. (See FENCING.)

Other (single family, townhouse, and manor home)

The following *do not* require an application:

- brass house numbers (shall not exceed 4" in height)
- brass kick plate
- doorbell
- door handle
- security glass (peephole)

Prohibitions

Except where otherwise noted, all prohibitions apply to single family houses, townhouses, and manor homes.

Air Conditioning Units

Window air conditioning units are prohibited.

Appliance Storage

The location of large appliances such as refrigerators and washing machines outside is prohibited.

Carpeting, Outdoor

Indoor-outdoor carpeting, Astroturf, or any other carpeting is prohibited on steps and walkways visible from the street.

Carports

Carports are prohibited.

Clotheslines

Clotheslines of any kind are prohibited.

Compost Bins (townhouse)

Compost bins are not permitted in townhouse yards.

Dog Runs

Dog runs and dog pens are prohibited.

Flag Poles, Permanent

Permanent and free-standing flagpoles are prohibited.

Satellite Dishes

Satellite dishes over 39 inches in diameter are prohibited.

Common Ground

Using in any manner or altering in any way, existing common property, which also includes but not limited to, removal of trees, branches on trees, common area brush and plantings

Maintenance guidelines

Property ownership includes the responsibility for maintenance of all structures and grounds which are a part of the property. This includes, but is not limited to, items such as mowing grass, removal of trash, and structural maintenance. Maintenance affects the visual character and economic values of the property and neighborhood, and in some cases, safety.

During construction

Construction materials required for major exterior alterations shall be stored so that impairment of views from neighboring properties is minimized. Construction materials shall not interfere with the normal ingress or egress from adjacent properties. No debris shall be allowed to accumulate during construction. Excess materials shall be immediately removed after completion of construction.

It is the responsibility of the applicant, or homeowner for whom the major alteration is being constructed, to repair any damage to neighboring properties and to return them to their original condition.

Erosion control

Each resident is responsible for seeing that his or her lot is protected from erosion and that storm drain structures are not blocked so as to cause additional erosion problems which will promote silt in ponds and stream valleys.

Exterior appearance

Residents are responsible for maintaining the exterior of their dwellings and any other structures on their lots, such as decks, fences, sheds, and playground type equipment. The following cases represent some of the conditions which would be considered a violation of the covenants:

- Peeling paint on trim
- Playground equipment, which is either broken, rusted, or in need of repainting
- Fences with either broken or missing parts
- Sheds with broken doors or in need of painting or other repairs
- Decks with missing or broken railings or parts, or parts in need of repainting
- Foundations in need of repainting
- Mildew on building exteriors
- Chimney crown flashing in need of painting or cleaning
- Windows in need of repair or replacement
- Wood rot on building exteriors in need of repair and paint
- Incorrect color schemes of “standard” colors on roofs, siding etc. and pursuant to the guidelines
- Landscaping in need of attention
- All types of driveways in need of resurfacing and repair

Firewood

Firewood shall be kept neatly stacked and located in such a manner so as to avoid adverse visual impact. All woodpiles must be located in the rear or side yard in such a manner as to avoid adverse visual impact on neighboring properties. Firewood may not be stored on common area. Woodpiles shall not exceed 4 feet in height and shall contain firewood only. It is suggested that plastic covers be in unobtrusive colors such as clear, black, dark brown, or dark green. Homeowners should be aware that placing woodpiles too close to the house (usually within 50 feet) may void a termite warranty.

Lawns

(single family and manor home)

Lawns need to be mowed at regular intervals, maintaining a maximum height of 6 inches. Single family homeowners are responsible for mowing and trimming to the street. Lawns that have died shall be re-established with the next growing season. Planted beds must be weeded and maintained.

(townhouse)

Lawns need to be mowed at regular intervals, maintaining a maximum height of 6 inches. Lawns that have died shall be re-established with the next growing season. Planted beds must be weeded and maintained.

Mailboxes

Mailboxes shall be kept in good condition. Peeling paint, rust, dents, and missing doors are not acceptable.

Pesticides, herbicides, and fertilizers

Care in application is extremely important along ponds and waterways, near neighborhood play areas and tot lots, and near adjacent residences. Avoid the use of pesticides and herbicides if possible.

Trash containers

Trash is to be placed in closed containers which have been manufactured for trash storage. Trash cans shall be stored out of view at all times, except on days of collection. Screening, fencing, or landscaping may be used where trash storage space is not available. Such screening or fencing shall be applied for and approved.

Trash removal

All residents are responsible for picking up litter on their property and preventing windblown debris from originating on their land. ***At no time is open space or common area considered a dumping ground. Organic debris such as leaves, grass clippings, and branches may not be dumped on common area.*** Countryside encourages recycling in accordance with Loudoun County ordinances.

Construction requirements

County permits

The applicant is responsible for meeting all Loudoun County requirements and securing all necessary permits.

Quality of work

It is presumed that all exterior modifications and construction will be performed at a high level of quality with all members appearing plumb and level, in an aesthetically acceptable manner, and requiring only normally expected maintenance. Should there be a question of quality of work, whether or not there is compliance with criteria under the maintenance guidelines contained herein, the applicant will be responsible for corrections as necessary to bring the quality to an acceptable level.

Timeliness

Timely completion of projects is necessary in order to minimize objectionable or nuisance situations as well as potential safety hazards. The alteration authority granted by the approved application will be revoked automatically if the alteration requested has not commenced within 180 days of the approval of the application or been completed within one year.

Vehicle parking

Please contact the Proprietary Management Office for current parking Resolutions.

Appendix A. – Standards and Neighborhood Guidelines

CountrySide Boulevard Approved Standard

Fence Design Guidelines

A uniform landscaping plan had been developed along CountrySide Boulevard. The Proprietary, either through limited access, screening easements or through its fee simple ownership of common areas bordering the Rokeby Ridge western portion of CountrySide Boulevard, retains all maintenance and landscaping responsibility in this area.

To complement the uniform landscaping plan, a uniform 4' foot estate design has been adopted for Rokeby Ridge homeowners electing to install fencing along the Boulevard. This continuity in fence design serves to enhance the overall aesthetic appearance along the Boulevard, thereby safeguarding both individual and collective property values. Application for this fence installation, like any exterior alteration or addition, flows through the Design Review Committee.



Townhouse Approved Standard fencing

The approved property-line fence standard is merely a continuation of the existing fence installed by your builder. The aesthetic intent is to retain a continuity in fence design, materials, color, etc. Please ensure that the fence continuation matches the existing builder installed fence.

Be certain to state on your application request the location of your unit, i.e., interior or end-unit. Be specific on your site plan to indicate the proposed location, particularly if you are an end-unit requesting side yard fencing. Indicate materials, design, etc. including gate installation as well.

Standard fence applications do NOT require signatures of neighbors, only the applicant's signature on the Application Request form.

Board on Board Property Line Fencing and Gate

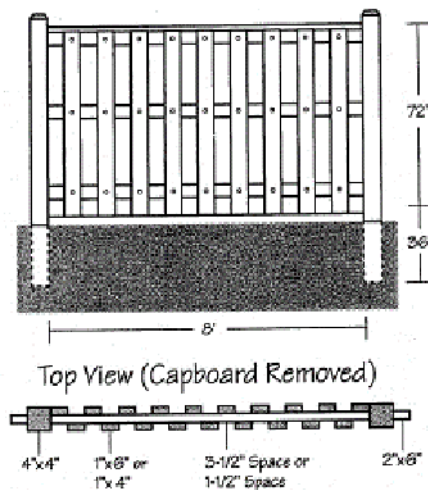

NOTES:

- Vertical boards alternate on either side so as to give same appearance to both sides
- Runners are toe nailed to center of posts.
- Fences 6' high have 3 runners.

Material

Posts: 4 x 4 Pressure treated pine or equal

Runners: 2 x 4 x 8 Kiln dried Hem/Fir

Vertical Boards: 1 x 4 Pressure treated pine or equal for Scarborough townhouses

1 x 6 Pressure treated pine or equal for Globe townhouses

Capboard: 1 x 4 x 8 Pressure treated pine or equal

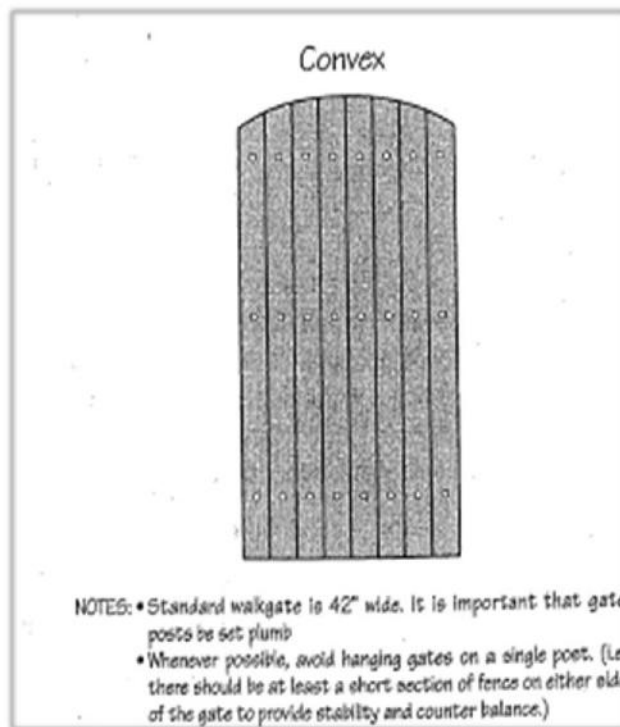

Post spacing is 8 feet between posts (if building on grade, set closer) bottom runner is 6 inches off ground and toe nailed to posts. Top runner is installed at the overall height of fence. Runners should be toe nailed to posts in the center allowing vertical boards to be flush with face of post. Nail on vertical boards, starting on one side, butting vertical board against post. Use a 1-1/2" wide spacer (between the 4" boards on Scarborough* townhouses) or a 33/4" spacer (between the 6" boards on Globe* * townhouses) and install the remaining vertical boards on that side. After one side is completed move to other side and install vertical boards in the same manner, making sure that they screen the spacing of the opposite side. It's a good idea not to completely nail the boards to runners until you are sure that your spacing is even. Check the plumb of your vertical boards periodically; make sure that they are straight after all vertical boards are in place; complete nailing. Install a 1" x 4" cap board between extended posts. Post top should extend approximately 1 inch above fence top. Install aluminum caps on posts to shed water.

*Scarborough townhouses are the contemporary Colonials in Welbourne and Morven.

* Globe townhouses are the remaining traditional Colonials and Tudors in all townhouse areas

Requirements for Standard Townhouse Decks and Patios

Standard application requests require an application be approved by the On-Site Manager or the DRC Coordinator. If the On-Site Manager or the DRC Coordinator determines an application to be questionable in following the criteria listed below, he/she may, at his/her discretion, submit the application for formal review. The following criteria shall be followed in order for a townhouse deck application to be approved as a standard. An applicant wishing to deviate from the following guidelines is encouraged to do so; however, such application shall be subject to the formal review procedures. Please refer to the attached cover sheet for examples and items requiring inclusion in application.

Location

Decks shall be restricted to the rear yard.

Size

Upper Level - The length of the deck shall not exceed one-half (1/2) of the rear yard from the back of the house, or twenty feet (20'), whichever is less. The height of the deck shall not exceed the bottom of the rear doorframe on the main level. The width of the deck must be at least one foot (1') from each side of the property line.

Ground Level - Ground level decks are considered those decks not more than 30" off the ground. The length of the ground level deck shall not exceed one-half (1/2) of the rear yard from the back of the house, or twenty feet (20'), whichever is less. The width of the ground level deck may extend to each side of the property line.

Railing

Standard railing shall be considered vertical picket railing thirty-six inches (36") in height, which is the minimum County requirement. Spacing between pickets shall not exceed six inches (6") on center. Railing is not required on ground level decks. If the "broom sweep" style of railing is used, spacing shall be no more than six inches (6") between the deck floor and bottom horizontal rail.

Stairs

The size of the stairs shall be included in the overall length and width of the deck and cannot exceed the criteria indicated above.

Color and Materials

All lumber used for standard deck construction shall be pressure-treated pine or naturally weather-resistant wood such as cedar or redwood and shall be left to weather naturally, or of a composite material such as Trex or TimberTech.

Lattice

Lattice shall be considered standard only on ground level decks provided it does not exceed the height of the deck floor. Deviations from the above shall be subject to the formal committee review process.

Benches

Benches shall be defined as backless seats for two or more people and shall be considered standard provided the height does not exceed one-half (1/2) of the height of the railing, if any, or 18". It is recommended that appropriate safety measures be exercised in cases where a ground level deck request contains no railing.

Patios

Patios shall be considered ground level paved space either brick, stone, or concrete. Patios are restricted to rear yards and shall adjoin the residence. The length of the patio shall not exceed one-half (1/2) of the rear yard from the back of the house, or twenty feet (20'), whichever is less. The width of the patio may extend to each side of the property line. Appropriate measures shall be exercised to ensure that drainage patterns are not affected. Landscape timbers may be used as a border provided the height of the timber is flush with the patio.

Townhouse Patio Door Standards

Globe *Colonial* Townhomes Foxfield

Replacement Patio doors shall be white in color and shall have grids. These Patio door guidelines apply to ALL Globe Colonial Townhouses in Foxfield.

No signatures are required from neighbors for a standard application request. Deviations from this standard must be prepared according to the normal approval process.

Globe *Colonial* Townhomes Oakridge and Welbourne

COURT	NUMBER	COLOR
Benton Court	All Townhomes	White
Dulany Court	All Townhomes	White
Felsted Court	ALL townhomes	White
Finchingfield Court	ALL townhomes	White
Mosby Court	All Townhomes	White
Redlin Court	All Townhomes	White
Sulgrave Court	ALL townhomes	White
Waltham Court	ALL townhomes	White

Oakridge and Morven *Tudor* Townhouses Patio Door Standards

Replacement Patio doors shall be dark brown in color and shall have grids. If grids are preferred, they shall be diamond style with dark brown grids. These Patio door guidelines apply to all Tudor Townhouses in Oakridge and Morven located on Chelmsford Court, Lyndhurst, and Millard Court.

No signatures are required from neighbors for a standard application request. Deviations from this standard must be prepared according to the normal approval process.

COURT	NUMBER	COLOR
Chelmsford Court	ALL townhomes	Dark Brown
Lyndhurst Court	ALL townhomes	Dark Brown
Millard Court	ALL townhomes	Dark Brown

Morven and Welbourne Scarborough Townhouses

Replacement Patio doors shall be dark brown in color and shall have grids. These Patio door guidelines apply to all Scarborough Townhouses in Oakridge and Morven located on Aldridge Court, Haxall Court, Paxton Court, and Ludwell Court. Berkley Court, Conoy Court, Jermyn Court, Nicholson Court, Hopton Court, and Vandercastle Road

No signatures are required from neighbors for a standard application request. Deviations from this standard must be prepared according to the normal approval process.

COURT	NUMBER	COLOR
Aldridge Court	ALL townhomes	Dark Brown
Haxall Court	All Townhomes	Dark Brown
Lyndhurst Court	ALL townhomes	Dark Brown
Ludwell Court	All Townhomes	Dark Brown
Paxton Court	All townhomes	Dark Brown

Foxfield Townhouses Entry Door Standards

These entry door “Standards” apply to the townhouses located in Foxfield. Replacement entry doors shall be steel or fiberglass. Colorless etched glass or silver or gold leaded glass is permitted. Stained glass doors and wood grain styles are prohibited.

Please indicate on the application form the style of your choice as illustrated below. Also indicate the color of your selection and its relationship to existing colors of the townhouse and the neighborhood.



Foxfield Townhouses Entry Door Standards, Cont'd



Foxfield Townhouses *Rear Entry Door Standard*

This entry door “Standard” applies to the townhouses located in Foxfield. Replacement Rear Entry Doors shall be steel or fiberglass. Colorless etched glass or silver or gold leaded glass is permitted. Stained glass doors and wood grain styles are prohibited.

Please indicate on the application form the style of your choice as illustrated below. Also indicate the color of your selection and its relationship to existing colors of the townhouse and the neighborhood.

If a “standard” door style is chosen and the color will remain the same as existing, the Design Review Coordinator can consider it a “standard” application for approval. No signatures are required from neighbors for a standard application request.



Morven Tudor Townhouse Entry Door Standards

These entry door “Standards” apply to the Tudor townhouses located in Morven. The Morven Tudor townhouses encompass the following streets, Lyndhurst Court and Millard Court.

Replacement entry doors shall be steel or fiberglass. Colorless etched glass or silver or gold leaded glass is permitted. Stained glass doors and wood grain styles are prohibited.

Please indicate on the application form the style of your choice as illustrated below. Also indicate the color of your selection and its relationship to existing colors of the townhouse and the neighborhood

If a “standard” door style is chosen and the color will remain the same as existing, the Design Review Coordinator can consider it a “standard” application for approval. No signatures are required from neighbors for a standard application request.



Morven Tudor Townhouse Entry Door Standards Cont'd

The “standard” colors for doors style for the Morven Tudor Townhouses are “Old Colonial Red”, “Deep Forrest Brown”, “Sugarloaf” and “Super White” by McCormick Paints.

Morven Scarborough Townhouse Entry Door Standards

These entry door “Standards” apply to the Scarborough townhouses located in Morven. The Scarborough townhouses encompass the following streets: Aldridge Court, Ludwell Court, Haxall Court and Paxton Court.

Replacement entry doors shall be steel or fiberglass. Wood grain styles are prohibited.

Please indicate on the application form the style of your choice as illustrated below. Also indicate the color of your selection and its relationship to existing colors of the townhouse and the neighborhood.

If the color and style remain the same the Design Review can consider it a “standard” application for approval. No signatures are required from neighbors for a standard application request.



Oakridge Globe Townhouses Entry Door Standards

These entry door “Standards” apply to the Globe townhouses located in Oakridge. The Oakridge Globe townhouse neighborhood encompasses the following streets: Felsted Court, Finchingfield Court, Sulgrave Court and Waltham Court.

Replacement entry doors shall be steel or fiberglass. Colorless etched glass or silver or gold leaded glass is permitted. Stained glass doors and wood grain styles are prohibited.

Please indicate on the application form the style of your choice as illustrated below. Also indicate the color of your selection and its relationship to existing colors of the townhouse and the neighborhood.

If a “standard” door style is chosen and the color will remain the same as existing, the Design Review Coordinator can consider it a “standard” application for approval. No signatures are required from neighbors for a standard application request.



Oakridge Tudor Townhouses Entry Door Standards

These entry door “Standards” apply to the Tudor townhouses located in Oakridge. The Oakridge Tudor townhouse neighborhood is Chelmsford Court.

Replacement entry doors shall be steel or fiberglass. Colorless etched glass or silver or gold leaded glass is permitted. Stained glass doors and wood grain styles are prohibited.

Please indicate on the application form the style of your choice as illustrated below. Also indicate the color of your selection and its relationship to existing colors of the townhouse and the neighborhood.

If a “standard” door style is chosen, and the color will remain the same as existing, the Design Review Coordinator can consider it a “standard” application for approval. No signatures are required from neighbors for a standard application request.



Welbourne Townhouse Entry Door Standards

These entry door “Standards” apply to the Scarborough and Globe townhouses located in Welbourne.

Replacement entry doors shall be steel or fiberglass. Colorless etched glass or silver or gold leaded glass is permitted. Stained glass doors and wood grain styles are prohibited.

Please indicate on the application form the style of your choice as illustrated below. Also indicate the color of your selection and its relationship to existing colors of the townhouse and the neighborhood.

If a “standard” door style is chosen, and the color will remain the same as existing, the Design Review Coordinator can consider it a “standard” application for approval. No signatures are required from neighbors for a standard application request.

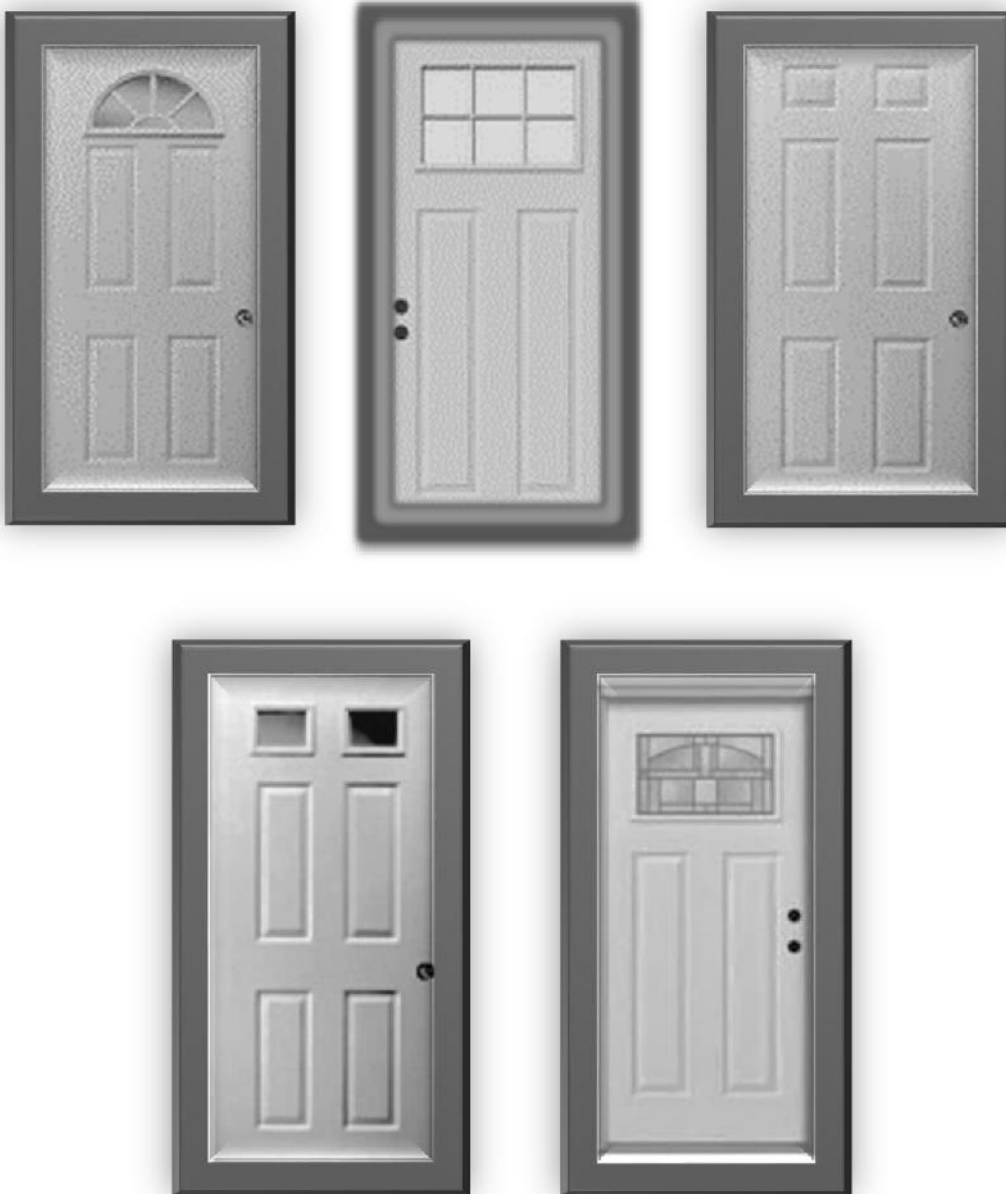

Welbourne Townhouse *Rear* Entry Door Standard

This entry door “Standard” applies to the Globe townhouses located in Welbourne.

Replacement entry doors shall be steel or fiberglass. Colorless etched glass or silver or gold leaded glass is permitted. Stained glass doors and wood grain styles are prohibited.

Please indicate on the application form the style of your choice as illustrated below. Also indicate the color of your selection and its relationship to existing colors of the townhouse and the neighborhood.

If a “standard” door style is chosen, and the color will remain the same as existing, the Design Review Coordinator can consider it a “standard” application for approval. No signatures are required from neighbors for a standard application request.



Belmont - Neighborhood III- Storm Door Standards

These storm door guidelines apply to Belmont Neighborhood III, of CountrySide, Single Family Homes, comprising sections: 2-B, 2-B-i, 2-B-2, 2-C, 2-C-i, 2-C-2, 2-D, 2-B, 2- F, 2-G, 3-A, 3-A-2, 3-A-3, 3-B,3-B-4, and 3-F.

The Belmont Single Family Homes encompass all the following streets: Austen Court, Awsley Court, Bedford Drive, Bentley Drive, Braxton Drive, Carrolton Road, Crisswell Court, Cumberland Court, Devonshire Court, Exeter Court, Foxmore Court, Halifax Court, Lindenwood Court, Lipscomb Court, Newland Court, Oakdale Court, Rawlston Court, Webley Court, Westmoreland Drive, Wickham Court, Wiltshire Court, and Worthington Court.

The approved storm door styles are as follows:

Front Door or Side Entry Doors Visible from Street

All models may choose only the following styles: Full View or Full View with Kick plate, as illustrated below. The color of the storm door must match either the door color or the trim color.

Side or Rear Entry Doors Not Visible from Street

All models and elevations may choose any of the styles illustrated below. In all cases the color of the storm door must match either the door color or the trim color.

The guidelines recognize storm doors already approved, both installed and awaiting installation, in Belmont Single Family Homes. Should the storm doors already approved and in place require replacement at some future date, the intent of this policy is to require that the replacement storm door conforms to this resolution.

No signatures are required from neighbors for a standard application request. You do not have to attach this standard sheet, simply indicate that you have read the specifications herein. Your application must state the color of the proposed storm door and what house color it is matching. Deviations from this standard must be prepared according to the normal approval process.

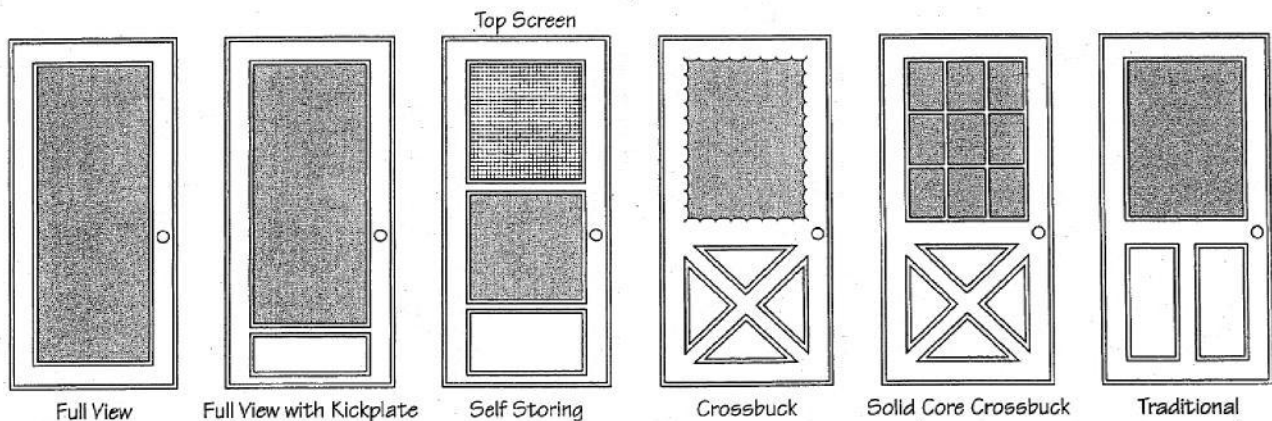

Morven Single Family Homes Storm Door Standards

These storm door guidelines apply to Morven Neighborhood VII, of CountrySide, Single Family Homes, comprising Sections 6-A, 6-B, 6-C, and 6-D.

The Morven Single Family Homes encompass all or part of the following streets: Byron Court, Griswold Court, Harrow Court, Rutledge Court, Teasdale Court, Thales Way, Vinson Court, and Whittingham Circle.

The approved storm door styles are as follows:

Front Doors

All models and elevations (architectural style of house front) may choose Full View, Full View with Kick plate, or Self-storing, as illustrated below. The color of the storm door must match either the door color or the trim color. Self-storing, however, must match the color of the door when used in front of the home.

Side or Rear Doors

All models and elevations may choose any style illustrated below. In all cases, the color of the storm door must match either the door color or the trim color.

The guidelines recognize storm doors already approved, both installed and awaiting installation in Morven Single Family Homes. Should the storm doors already approved and in place require replacement at some future date, the intent of this policy is to require that the replacement storm door conform to this resolution.

No signatures are required from neighbors for a standard application request. You do not have to attach this standard sheet - simply indicate that you have read the specifications herein. Your application must state the color of the proposed storm door and what house color it is matching. Deviations from this standard must be prepared according to the normal approval process.

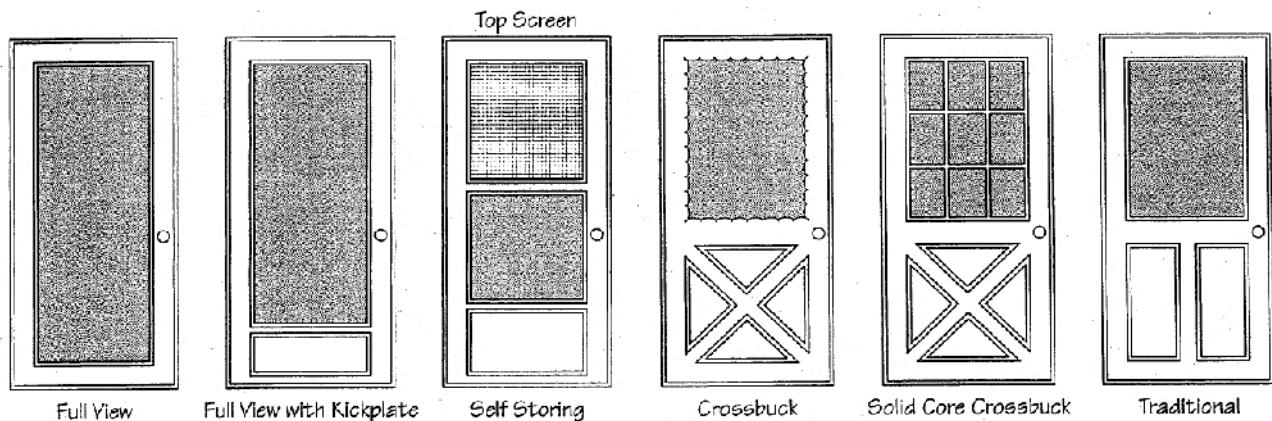

Morven Tudor Townhouses Storm Door Standards

These storm door standards apply to the Morven Tudor Townhouses located on Lyndhurst Court and Millard Court

Please indicate the style of your choice listed below on the original Application Request form. You do not have to attach a copy of the standard to the application.

NO signatures are required of neighbors on the application. Please make certain that you sign the application original as the Applicant.

Please indicate the color of your selection and its relationship to existing colors on the parent structure.

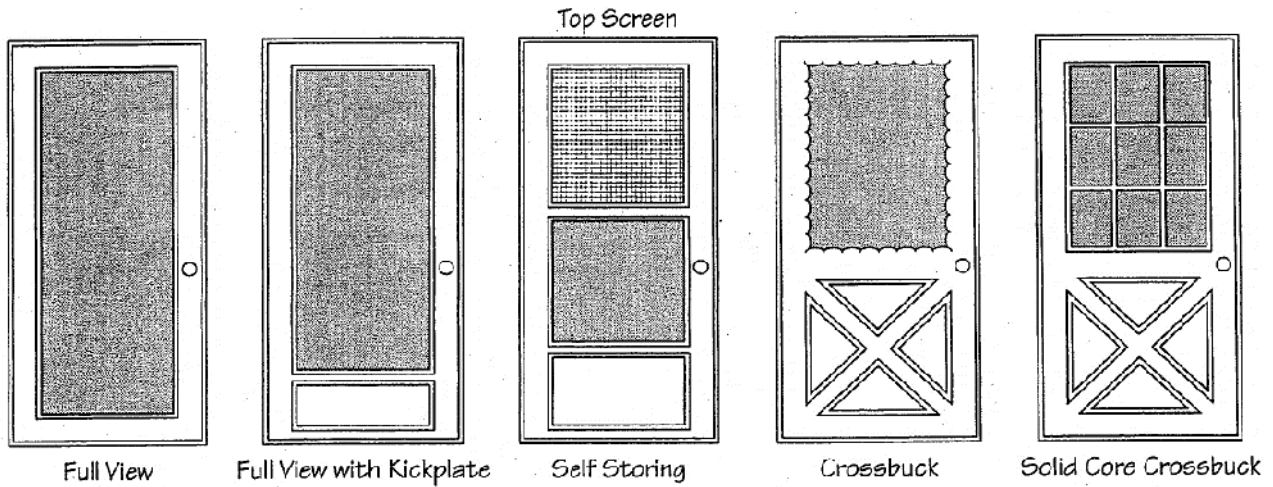

Morven Scarborough Townhouses Storm Door Standards

These storm door standards apply to the Morven Scarborough Townhouses located on Aldridge, Haxall, Ludwell, Lyndhurst, Millard, and Paxton Courts.

Please indicate the style of your choice listed below on the original Application Request form. You do not have to attach a copy of the standard to the application.

NO signatures are required of neighbors on the application. Please make certain that you sign the application original as the Applicant.

Please indicate the color of your selection and its relationship to existing colors on the parent structure.

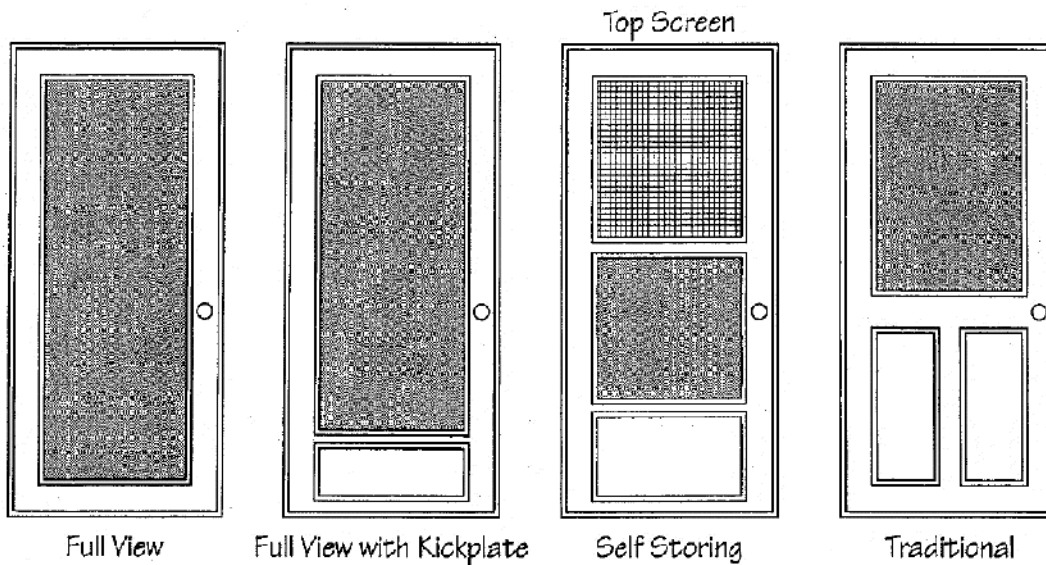

Oakridge Single Family Homes Storm Door Standards

These Storm Door Guidelines apply to the Oakridge Neighborhood of CountrySide, Single Family Homes, comprising Sections 5-A, 5-B, 5-C, 5-D, 5-E and: 5-F.

The Oakridge Single Family homes encompass all or part of the following streets: Amersham Court, Christopher Lane, Dunbar Way, Forester Court, Lowry Court, Owens Court, Prescott Court, Rutherford Circle, Steed Place, Stafford Court and Thorton Court.

The approved storm door styles are as follows:

- Full View
- Full View with Kick plate
- Self-Storing with screen/window combination

These Storm Door styles are for all models and elevations and may be used on front, rear or side entry doors. The Full View and Full View with kick plate may match either the door or the trim of the house. The Self-Storing **MUST** match the door.

The guidelines recognize storm doors already approved, both installed and awaiting installation, in Oakridge Single Family Homes. Should the storm doors already approved in place require replacement at some future date, the intent of this policy is to require that the replacement storm door conform to this resolution.

No signatures are required from neighbors for a standard application request. Your application must state the color of the proposed storm door and what house color it is matching. Deviations from this standard must be prepared according to the normal approval process.

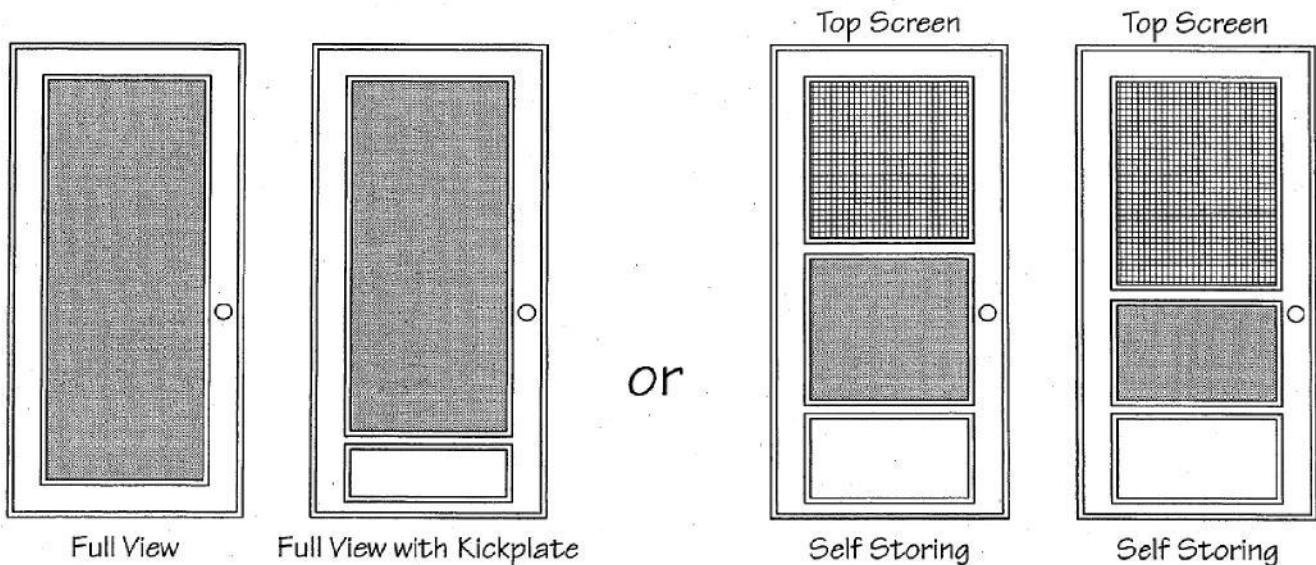

Oakridge Globe Colonial Townhouses Storm Door Standards

These storm door guidelines apply to the Globe Colonial townhouses located in Oakridge which encompass the following streets: Felsted Court, Finchingfield Court, Sulgrave Court, and Waltham Court.

Please indicate on the application form the style of your choice as illustrated below. Also indicate the color of your selection and its relationship to existing colors of the townhouse. Please note that the color of the storm door must match either the door color or the trim color.

No signatures are required from neighbors for a standard application request. Deviations from this standard must be prepared according to the normal approval process.

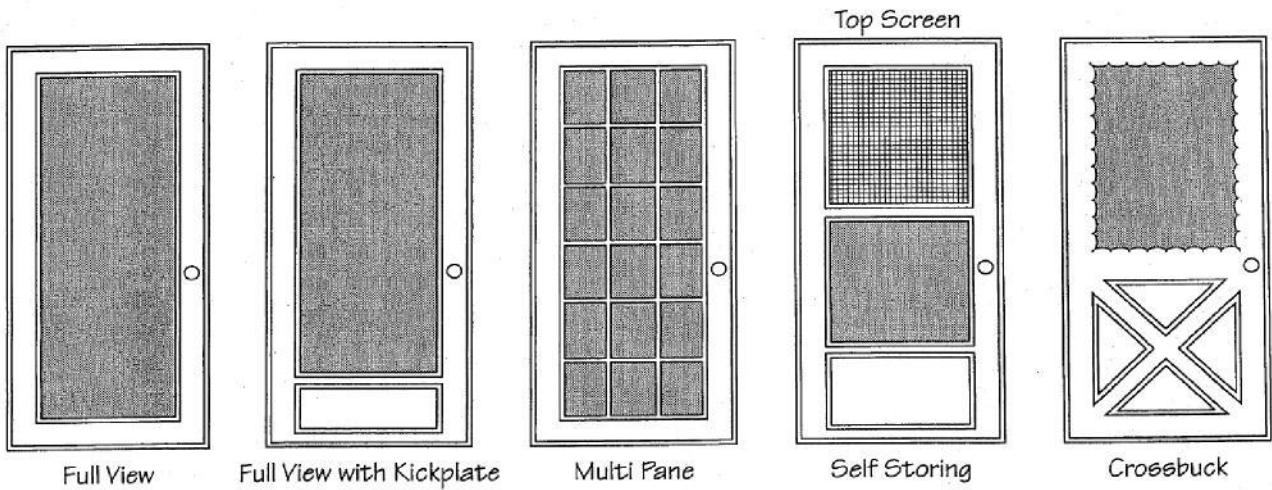

Oakridge Tudor Townhouses Storm Door Standards

These storm door guidelines apply to the Tudor Townhouses located on Chelmsford Court.

Please indicate on the application form the style of your choice as illustrated below. Also indicate the color of your selection and its relationship to existing colors of the townhouse.

No signatures are required from neighbors for a standard application request. Deviations from this standard must be prepared according to the normal approval process.

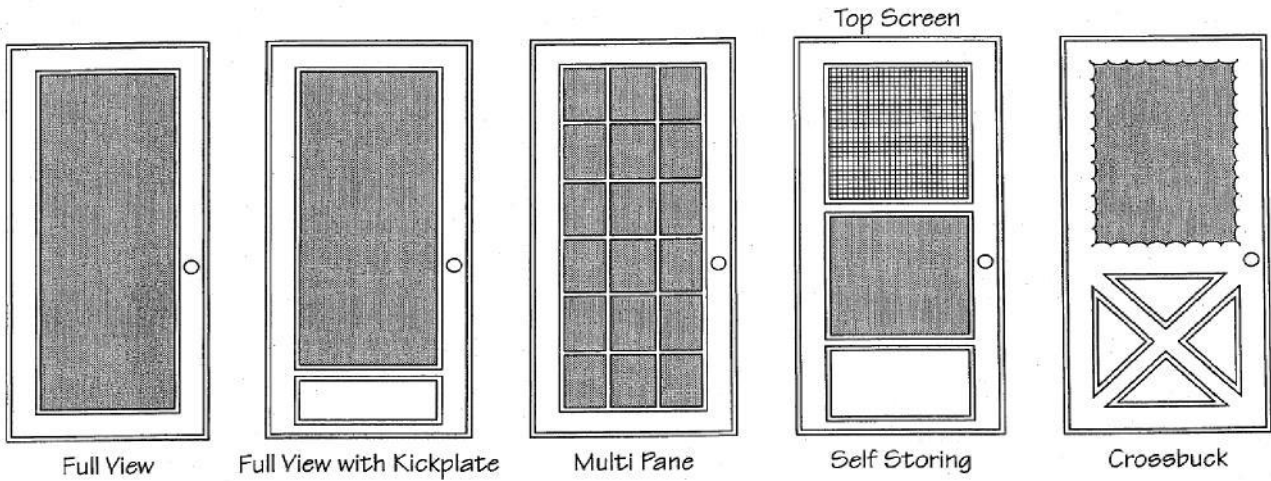

Oatlands Storm Door Guidelines

These storm door guidelines apply to the Oatlands neighborhood (IV) of CountrySide comprising Sections 3-C, 3-D, 3E, 3-B-i, 3-E-2, 4-A, 4-B, and 4-C.

The Oatlands neighborhood encompasses all or part of the following streets: Bentmoor Court, Brinks Court, Brookmeade Court, Darian Court, Dudley Court, Fenton Wood Drive, Ferguson Court, Glengyle Court, Glengyle Lane, Jeremy Court, McCarty Court, McPherson Circle, Meskill Court, Selden Court and Whaley Court.

The approved storm door styles are as follows:

- Full View
- Full
- Self-Storing

In all cases, the color of the storm door must match one of the following: the front door color, the trim color or the siding color.

These guidelines recognize those storm doors already approved, both installed and awaiting installation, in the Oatlands neighborhood. Should the storm doors already approved and in place require replacement at some future date, the intent of this policy is to require that the replacement storm door conform to this resolution.

No signatures are required from neighbors for a standard application request. You do not have to attach this standard sheet - simply indicate that you have read the specifications herein. Your application must state the color of the proposed storm door and what house color it is matching. Deviations from this standard must be prepared according to the normal approval process.

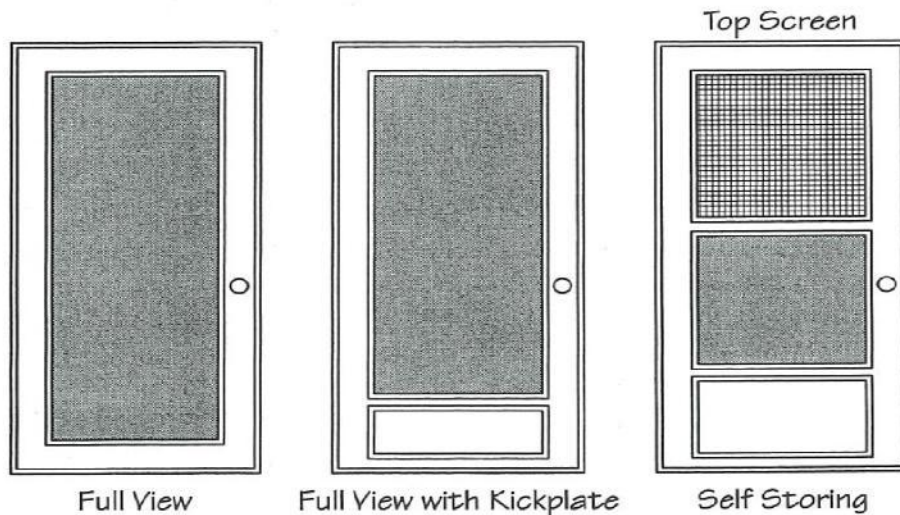

Rokeby Ridge Single Family Homes Storm Doors Standards

Front Doors: All models and elevations (architectural style of house front) may choose Full View, Full View with Kick plate or Self Storing, as illustrated below. Any models/elevations which have a cross buck front door may also select Solid Core or Cross buck, as illustrated below. In all cases, the color of the storm door must match either the door color or the trim color.

Side or Rear Doors: All models and elevations may choose any of the styles illustrated below. In all cases, the color of the storm door must match one of the following: the door color, the trim color, or the siding color.

No signatures are required from neighbors for a standard application request. You do not have to attach this standard sheet - simply indicate that you have read the specifications herein. Your application must state the color of the proposed storm door and what house color it is matching. If you are proposing Solid Core Cross buck or Cross buck for a front storm door, your application must also include the model and elevation of your house. Deviations from this standard must be prepared according to the normal approval process.

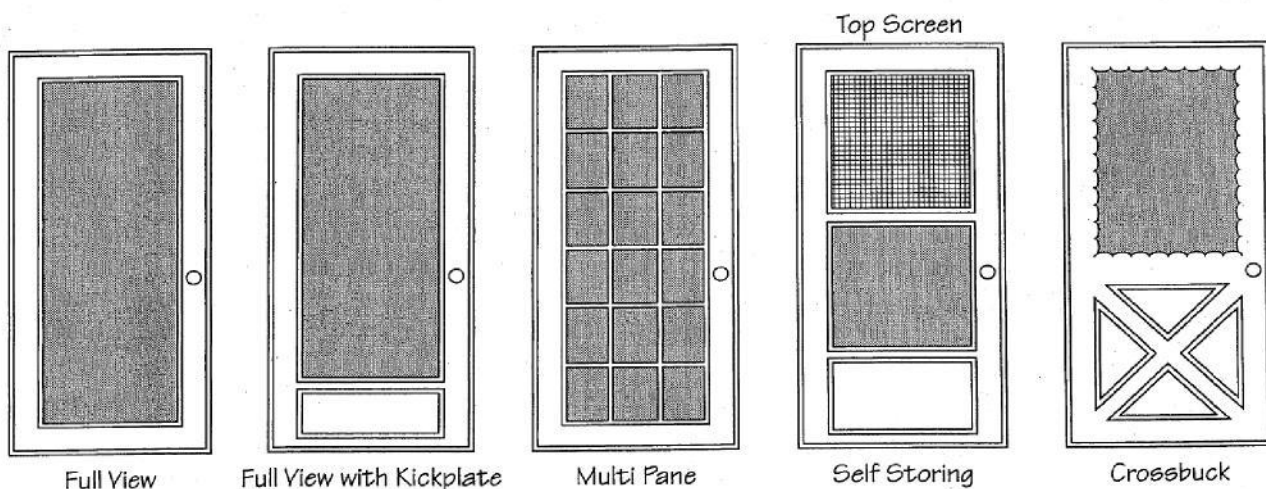

Welbourne Standard Storm Doors (Globe townhouses)

These storm door guidelines apply to the Globe townhouses located in Welbourne, which encompass the following streets: Benton Court, Dulany Court, Mosby Court and Redlin Court.

Please indicate on the application form the style of your choice as illustrated below. Also indicate the color of your selection and its relationship to existing colors on the townhouse. Please note that the color of the storm door must match either the door color or the trim color.

No signatures are required from neighbors for a standard application request. Deviations from this standard must be prepared according to the normal approval process.

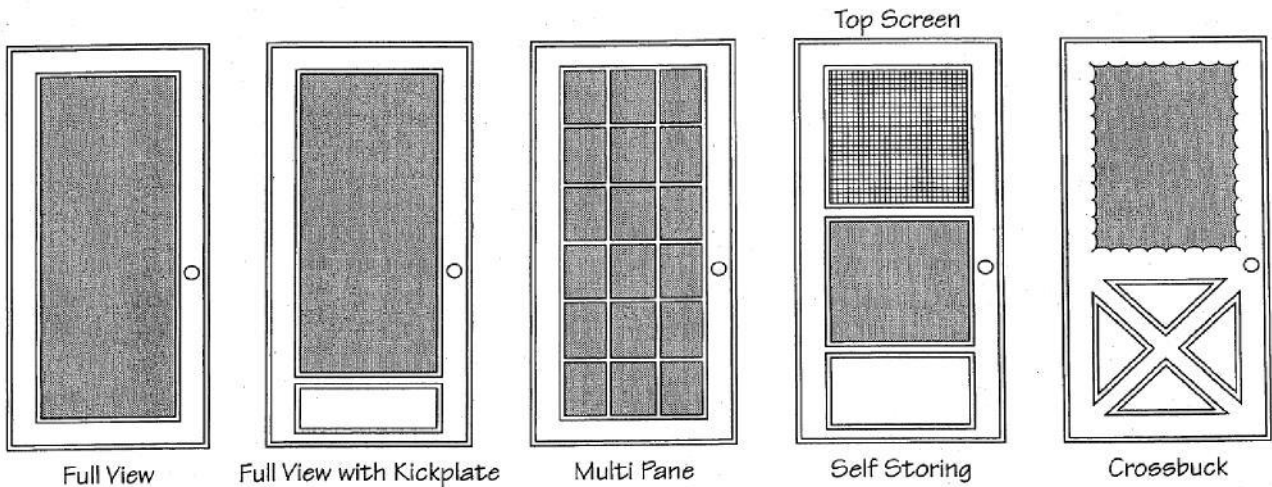

Welbourne Standard Storm Doors (Scarborough townhouses)

These storm door guidelines apply to the Scarborough townhouses located in Welbourne, which encompass the following streets: Berkeley Court, Conoy Court, Hopton Court, Jermyn Court, Nicholson Court and Vandercastle Road.

Please indicate on the application form the style of your choice as illustrated below. Also indicate the color of your selection and its relationship to existing colors of the townhouse. Please note that the color of the storm door must match either the door color or the trim color.

No signatures are required from neighbors for a standard application request, Deviations from this standard must be prepared according to the normal approval process.

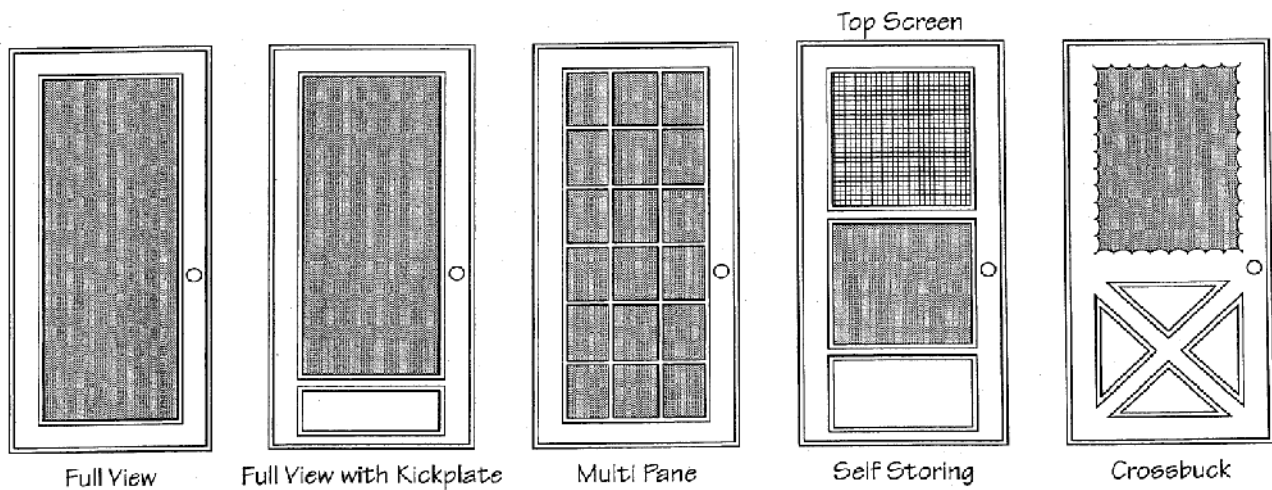

Standard for Garage Door Material Change All Neighborhoods with Garages

The following criteria shall be followed in order for an application to be approved standard for a garage door material change. An applicant wishing to apply for a non-standard door may do so. This “standard” shall apply to all single family, townhouse, and manor homes.

No signatures are required from neighbors for a “standard” application request.

The standard is as follows:

A garage door material change (from wood to metal or vinyl) may be approved as a standard application if the replacement door is the same as the original door in design (i.e., windows/no windows) and color.

Your application must state that the replacement garage door is the same in design and color as the original door.

Standard for Walkways

(Single Family)

The following criteria shall be followed in order for replacement walkways to be approved as a standard application. A replacement walkway or overlay to a front stoop and steps may be approved as a standard if the existing footprint is maintained, and is constructed of slate, brick, pavers, stepping- stones or un-colored and un-stamped concrete as used in a standard walkway. Landscape timbers (**4" x 4" pressure treated wood**) may be used as a border. All other types of walkway material would be subject to formal review by the Neighborhood Advisory Council and Design Review Committee. An applicant wishing to deviate from the following guidelines, is encouraged to do so; however, such application shall be subject to formal review procedures. All other types of walkway material would be subject to formal review by the Neighborhood Advisory Council and Design Review Committee. No signatures are required from neighbors for a standard application request.

(Manor Homes)

A replacement walkway may be approved as a standard if the existing footprint is maintained, and is constructed of slate, brick, pavers, stepping- stones or un-colored and unstamped concrete as used in a standard walkway. Landscape timbers (**4" x 4" pressure treated wood**) may be used as a border. This standard shall apply to manor homes. All other types of walkway material would be subject to formal review by the Neighborhood Advisory Council and Design Review Committee. No signatures are required from neighbors for a standard application request.

(Townhouse)

Townhouse front walkways shall be the same style and material as the original builder provided.

Application Contents - site plat (addition), color photo of affected area, dimensions, elevation, materials, color, style of house

Standard for Material Change (Trim) (All Neighborhoods)

The following criteria shall be followed in order for a standard application to be approved for a material change to the exterior trim of a dwelling. An applicant wishing to deviate from the standard is encouraged to do so. However, such applications shall be subject to formal review procedures. This standard shall apply to all single family, townhouses, and manor homes.

No signatures are required from neighbors for a standard application request.

The standard is as follows:

The replacement of all exterior wood trim with vinyl-covered aluminum wrap, fiber cement or PVC may be approved as a standard application as long as the trim matches the approved wood trim color. Trim shall match in color on all sides of the home.

Applications must state that the color of the trim or trim wrap matches the approved color of wood trim color. The application also requires a color photo or sample of the proposed trim or trim wrap.

Exterior Lighting - Wattage Guidelines

Oatlands

These exterior lighting guidelines apply to the **Oatlands Neighborhood** IV of CountrySide comprising Sections 3-C, 3D, 3-E, 3-E-I, 3-E-2, 4-A, 4-B, 4-C and 4-D.

The Oatlands Neighborhood encompasses all or part of the following streets: Bentmoor Court, Brinks Court, Brookmeade Court, Darian Court, Dudley Court, Fenton Wood Drive, Ferguson Court, Glengyle Court, Glengyle Lane, Jeremy Court, McCarty Court, McPherson Circle, Meskill Court, Selden Court, and Whaley Court.

The maximum wattage of any single bulb in any type of an outside light fixture shall be 75 watts or its equivalent. The maximum wattage of any outside light fixture shall be 150 watts or its equivalent.

Oatlands Standard Mailbox Post Color

The standard mailbox post color for Oatlands is Duron Paints Mushroom White or its equivalent. No signatures are required from neighbors for a standard application request. Deviations from this standard must be prepared according to the normal approval process.

Oatlands Standard Basketball Equipment

Basketball goals and backboards have an aesthetic impact on neighborhoods. Unsuitably placed equipment can visually and functionally negate an otherwise desirable residential neighborhood. The proposed standard for Oatlands Neighborhood is as follows. Portable basketball poles that are to be removed from view after play are encouraged.

For homes that have garages, it is encouraged that permanent goals shall be attached over the garage, where possible.

Free-standing basketball poles are strongly encouraged to be located in rear yards. Applications that request poles be located in the front or side yards must be located a minimum of 10 feet from the property line. Poles shall be painted brown, dark green or black to blend with the natural surroundings; or be painted white or cream to match the house siding, whichever is less conspicuous.

Backboards for goals must be clear or painted white and free from all advertising, logo, etc. Driveways painted to resemble basketball courts are unacceptable.

Appendix B – Application Checklists

Color Change Checklist

Please read both sides of the attached application form and complete the specified portion on the front side. Your color change application **MUST** contain the following items and information. Please check off each item as you address it in your application. **INCOMPLETE APPLICATIONS WILL BE RETURNED.**

Please provide the following information below or on a separate page.

_____ areas to be repainted (i.e., headers above front windows,
trim around garage, front door, etc.)

_____ existing color of areas to be repainted

_____ color of corresponding areas of adjacent homes

_____ style of home (i.e., Victorian, contemporary, etc.)

_____ color of siding

_____ color of roof

_____ color of other painted areas that are not changing color

_____ One chip of each new color (Each chip should be at least 1" square.)

A chart of McCormick's Paints "Colonial Exterior Colors" is available at the Proprietary Office. These are the original colors used in most of CountrySide. If you are using one of those McCormick colors, you do not need to submit color chips.

Please see "Appendix A - Standards and Neighborhood Guidelines" in the Community Guidelines Handbook for more information.

Color Change Application Grid

Address: _____

Style of your home: _____

Item	Current Color (*current color MUST be stated)	Proposed Color (for item or area of change)
Siding*		
Trim*		
Shutters*		
Front Door*		
Roof*		
Other Area		
Other Area 2		
Other Area 3		
Other Area 4		
Other Area 5		

Color of Corresponding Area of Adjacent Homes:

Address:	Color:
1.	
2.	
3.	
4.	

Please attach
one (1)
color sample
Siding/Paint/Roof, etc.

Deck/Patio Application Checklist

Please read both sides of the attached application form and complete the specified portion on the front side. **INCOMPLETE APPLICATIONS WILL BE RETURNED.**

Your deck or patio application **MUST** contain the following items and information. Please check off each item as you address it in your application. A sample deck application is shown in Appendix C of the Community Guidelines Handbook.

1. Please indicate the following on a copy of your legal site plat/property plat. (The site plat should be located with your settlement documents.)

_____ location of deck or patio drawn to scale
_____ exact dimensions of deck or patio
_____ distances from deck or patio to both side property lines. (This shall be no less than one foot (1') for an upper-level deck. Ground level decks and patios may extend to the side property lines.)
_____ distance from rear property line
_____ length of back yard (from back of house to rear property line)

2. Please indicate the following on separate drawings.

_____ floorplan, with dimensions, of deck or patio (top view)
_____ specify location of benches (if any) on floorplan
_____ front elevation showing deck against house
_____ height of decking off ground
_____ style and height of railing (Height must be 36" and style must be vertical picket with spacing between pickets being 6" on center.)
_____ dimensions and elevation (side view) of steps

3. _____ Please indicate here:

- A. Type of wood _____ (must be pressure treated pine or a naturally weather-resistant wood)
- B. State that the wood will be left to weather naturally _____
- C. Specify if lattice will be used. _____ (Please note that lattice on ground level decks may not exceed the height of the deck floor.)

PROPOSED LATTICE ON UPPER-LEVEL DECKS MUST BE SUBMITTED FOR FORMAL REVIEW BY THE NAC AND DRC.

D. If benches will be used, specify height)

Bench height may not exceed one-half (1/2) of the height of the railing, if any, or eighteen inches

(18"). 4. **For Patios only:**

- A. Indicate type of material _____ (brick, stone, or concrete.)
- B. Indicate whether landscape timbers will be used (must be flush with the patio)

Enclosed Structure Application Checklist

Please read both sides of the attached application form and complete the specified portion on the front side. Your enclosed structure (room addition, screened porch, sunroom, etc.) application **MUST** contain the following items and information. Please check off each item as you address it in your application. **INCOMPLETE APPLICATIONS WILL BE RETURNED.**

1. Please indicate the following on a copy of your legal site plat. (The site plat should be located with your settlement documents.)

_____ location of structure drawn to scale
_____ exact dimensions of structure
_____ distances from closest points of structure to all property lines
_____ distance from closest point of structure to rear property line

2. Please indicate the following on (a) separate drawing(s).

_____ floor plan of structure (top view)
_____ **all** dimensions
_____ front and side elevations of structure, showing it against a full view of the house
_____ height off ground
_____ roof pitch (minimum is 3/12)
_____ dimensions, placement, and color of skylights
_____ dimensions and style of windows (Note that the style of new windows shall match the style of existing windows.)
_____ dimensions style and color of doors (Note that the style of new doors shall match the style of existing doors.)
_____ dimensions of screens
_____ indicate what kind of construction materials (siding, shingles, trim, etc.) will be visible and where (Note that the composition and color of all materials shall match exactly to those on the existing structure.)

Please see the Community Guidelines Handbook sections on DOORS, GUTTERS and DOWNSPOUTS, ROOM ADDITIONS/HOUSE EXPANSION, SCREENED PORCHES, SKYLIGHTS, and WINDOWS for more information.

Fence Application Checklist

Please read both sides of the attached application form and complete the specified portion of the front and rear sides. **Incomplete applications will be returned.**

Your fence application **MUST** contain the following items and information. Please check off each item as you address it in your application. A sample fence application is shown in Appendix C. of the Community Guidelines Handbook.

1. Please indicate the following on a copy of your legal site plat. (The site plat should be located with your settlement documents.)

_____ exact location of fence
_____ exact placement of all gates
_____ style of fencing on adjacent lots

2. Attach a drawing of a segment of the proposed fence and gate(s) indicating the following.

_____ style of fence by name (e.g., Gothic Picket, 6 Board Estate , etc.)
_____ style of gates by name (e.g.) Convex, Split Rail etc.)
_____ height of fence
_____ dimensions of gate (s)
_____ width of boards
_____ spacing between boards (if picket)

3. Please indicate the following below:

A. Type of Wood:

B. Color of wood (if fence is being stained or painted, **one color sample** and the **color of the house and trim must be specified.**)

Natural _____

Stain (name of color)

Paint (name of color)

Color of House_____

Color of House Trim

- C. Will wire mesh be used? Yes _____ No _____
If "yes", specify color Dark Green _____ Brown _____ Black

Please note that wire mesh shall be vinyl-coated; 2 by 3 inch rectilinear, attached to the inside of the fence and may not extend above the top rail.

- D. Number of Gates

- E. State that the Fence will be within **one inch (1")** of the property line Yes ___ No ___ If "No" please explain why.

- F. My Contract specifies the fence will be on my property line or inside (within one inch) of my property line. Encroachment on neighboring property is not allowed. It is my sole responsibility to ensure my proposed fence within one inch inside of, my property line. If there is any uncertainty or issue regarding fence location it is my (the applicant's) responsibility to secure a fence location survey prior to installing the fence. Should the location of the fence become an issue after installation, a survey to verify where the fence is located will be required and is the responsibility of the current owner of the property that contracted to install the fence.

Yes _____ No _____

- G. Will fence extend forward of the sight lines? Yes _____ No _____

If "yes", please explain why. (Refer to the Community Guidelines Handbook section on "Fences" for a definition of "sight line" and discussion of possible exceptions).

Lighting Application Checklist

Please read both sides of the attached application form and complete the specified portion on the front side. Your lighting application **MUST** contain the following items and information. Please check off each item as you address it in your application. **INCOMPLETE APPLICATIONS WILL BE RETURNED.**

- 1** Please indicate the following on a copy of your legal site plat. (The site plat should be located with your settlement documents.)

_____ exact location of each proposed lighting fixture.

_____ direction and approximate distance of light path (Note light path should not extend beyond your property line.)

- 2.** Please **provide** photograph or detailed drawing of fixtures indicating the following.

_____ wattage of each fixture

_____ height of each fixture (to top of ground level and non-decorative fixtures; to bottom and top of decorative fixtures.)

- 0.** Is lighting movement sensitive? _____ Yes _____ No

Please see the Community Guidelines Handbook section on LIGHTING for more information.

Shed Application Checklist

Single Family, Townhouse and Manor homes

Please read both sides of the application and complete the specified portions on the front side.
INCOMPLETE APPLICATIONS WILL BE RETURNED.

Your shed application **MUST** contain the following items and information. Please check off each item as you address it in your application. Specifications for sheds are contained in the appropriate Shed Guideline Handbook.

1. Please indicate the following on a copy of your legal site plat. (The site plat should be located with your settlement documents. If you do not have a copy, please call the Proprietary Office. In most instances, not always, a site plat has been retained in the unit file at the Proprietary office.)

_____ Exact location drawn to scale on the site plat

_____ Distance from house and fence

_____ Exact locations of deck and patio

0. Please provide detailed drawing of shed indicating the following.

_____ Height of Shed

_____ Width of Shed

_____ Length of Shed

Please provide the following on a separate page.

Style of Home

_____ Color of Siding on home

_____ Color of Roof on home

_____ Color of House trim

0. List all materials and colors to be used:

Window Check List

1. Current Material:
(wood, plastic, metal, vinyl)
New Window material:

2. Size

Will the replacement windows be the same size as the current windows?

Yes No (Please explain)

3. Style

Current window type: Double Hung Grids (Yes/No)

Casement

Sliding

Fixed

Replacement window type:

Double Hung Grids (Yes/No)

Casement

Sliding

Fixed

4. Current Window Color:

Replacement window color:

5. Type of House

Town House

Manor

Single Family

6. Style of House _____

(i.e., Tudor, Colonial, Cluster, Suncatcher, and Scarborough)

7. Product Information is attached. Yes No

Standard Townhouse Deck/Patio Application Checklist

Please read both sides of the attached application form and complete the specified portion on the front side.
INCOMPLETE APPLICATION WILL BE RETURNED

Your deck or patio application **MUST** contain the following items and information. Please check off each item as you address it in your application. A sample deck application is shown in Appendix C of the Community Guidelines Handbook.

1. Please indicate the following on a copy of your legal site plat. (The site plat should be located with your settlement documents.)

_____ location of deck or patio drawn to scale
_____ exact dimensions of deck or patio
_____ distances from deck or patio to both side property lines. (This shall be no less than one foot (1') for an upper-level deck. Ground level decks and patios may extend to the side property lines.)
_____ distance from rear property line
_____ length of back yard (from back of house to rear property line)

2. Please indicate the following on separate drawings.

_____ floor plan, with dimensions, of deck or patio (top view)
_____ specify location of benches (if any) on floor plan
_____ front elevation showing deck against house
_____ height of decking off ground
_____ style and height of railing (Height must be 36" and style must be vertical picket with spacing between pickets being 6" on center.)
_____ dimensions and elevation (side view) of steps

3. Please indicate here:

- A. Type of wood _____ (must be pressure treated pine or a naturally weather-resistant wood)
- B. State that the wood will be left to weather naturally _____
- C. Specify if lattice will be used. _____ (Please note that lattice on ground level decks may not exceed the height of the deck floor.) **PROPOSED LATTICE ON UPPER-LEVEL DECKS MUST BE SUBMITTED FOR FORMAL REVIEW BY THE NAC AND DRC.**
- D. If benches will be used, specify height. (Bench height may not exceed one-half (1/2) of the height of the railing, if any, or eighteen inches (18").

4. For patios only:

A. Indicate type of material _____ (brick, stone, or concrete).

B. Indicate whether landscape timbers will be used _____ (must be flush with the patio)

Standard Townhouse Fence Checklist

Please read both sides of the attached application form and complete the specified portion on the front side. **INCOMPLETE APPLICATIONS WILL BE RETURNED.**

Your fence application **MUST** contain the following items and information. Please check off each item as you address it in your application. Specifications for Standard Townhouse Fences are contained in Appendix A of the Community Guidelines Handbook.

1. Please indicate the following on a copy of your legal site plat. (The site plat should be located with your settlement documents.)

_____ exact location of fence

_____ exact placement of all gates

_____ dimensions of fence

2. Please indicate the following below.

_____ type of wood

_____ state that the wood will be left to weather naturally

_____ state that the fence will be within one inch (1") of the property line

Please see "Appendix A - Standards and Neighborhood Guidelines" in the Community Guidelines Handbook for more information.

Standard Townhouse Roof Checklist

1. Style
Current roof shingle style: _____
New roof shingle style: _____

2. Color
Current roof shingle color: _
Proposed roof shingle color:

0. Product Information and Roof Shingle Sample is attached with application. Yes_____ No_____

1. I understand that architectural/dimensional/hail resistant roof shingles are prohibited for the Tudor and Scarborough townhouses.
Yes _____ No _____

0. My Contract specifies the new roof shingle type and color as described in my application? Yes_____ No_____

Standard Walkway Checklist

Please read both sides of the attached application form and complete the specified portion on the front side. **INCOMPLETE APPLICATIONS WILL BE RETURNED.**

Your walkway application **MUST** contain the following items and information. Please check off each item as you address it in your application. Specifications for Standard Walkways are contained in Appendix A of the Community Guidelines Handbook.

1. Please indicate the following on a copy of your legal site plat. (The site plat should be located with your settlement documents. If you do not have a copy, please call the Proprietary Office. In most instances, not always, a site plat has been retained in the unit file.)
2. Please indicate the following standard material that will be used for the walkway below.

_____ slate

_____ stepping- stones

_____ small landscaping stones

_____ landscape timbers (4" x 4" pressure treated lumber) used as a border

Please see "Appendix A - Standards and Neighborhood Guidelines" in the Community Guidelines Handbook for more information.

Appendix C- Contents and Samples

Definitions

Each numbered guideline in the main body of this Handbook ends with a subsection labeled “Application Contents,” which lists what information must be included in an application for that particular type of alteration. The following are definitions of all the terms listed under “Application Contents.”

Site Plat (Addition) - Provide copy of the legal site plat (site location survey). Include an outline of the proposed alteration, accurately located and drawn to scale. Show distances to side and rear property lines from edge or point of proposed alteration that is closest to the property line.

Site Plat (Other) - Provide copy of the legal site plat (site location survey). Indicate location of proposed alteration.

Dimensions - Note height, length, and depth of proposed alteration. **Materials** - If more than one type of material is to be used, indicate which is being used and where.

Elevation - Provide accurate drawing of all exposed sides of the proposed alteration. If alteration is part of or attached to the house, include a drawing showing the house (or a significant portion thereof) as it will appear with alteration in place.

Color - Include eight color chips, at least one-inch (1”) square for surfaces to be painted, and one (1) fabric sample large enough to show at least one (1) square inch of each color for awnings. Indicate where color or colors will be applied; what colors are on the rest of the house; what colors are on neighboring houses on both sides.

Style of House - Note if manor home. Townhouses styles are colonial (Welbourne, Foxfield, Oakridge); Tudor styles (Morven, Oakridge); or Scarborough contemporary colonial (Welbourne, Morven). Single-family homes styles are Tudor, colonial/traditional, Georgian, Cape Cod, Victorian, Victorian carriage, contemporary carriage, Suncatcher. If you are unsure, provide a photo.

Checklist - when you pick up an application form at the Proprietary office, also get a checklist for the specific alteration you are proposing. The checklist lists and explains information that must be provided with the application. Currently, there are checklists for standard townhouse decks and patios, decks, standard townhouse fences, fences, enclosed structures, color changes, and lighting.

Following are some samples of correctly filled out, complete applications. These are **SAMPLES only**. Your application will differ in its details. Refer to the Community Guidelines Handbook subsection covering the alteration for which you are applying to determine exactly what must be included in your application. It may then be helpful to look through these samples for help on the level of detail needed by the DRC. Please remember that incomplete applications cannot be acted upon and will be returned. Although the sample application forms have been typed, you need only write legibly or print using black ink. The numbers listed under each sample correspond to the circled numbers on the sample application forms and attachments.

Sample 1 – Standard Storm Door

- 1. Full description of item indicating exactly which standard (i.e., Rokeby style B with color to match house trim) you are applying for**
- 2. Signatures are not required on applications for standard storm doors**

Sample 2- Standard Townhouse Deck

- 1. Application for Standard townhouse decks must include a completed Standard Townhouse Deck/Patio Application Checklist.**
- 2. Full description of alteration indicating that it is a Standard (“standard townhouse deck”).**
- 3. Deck dimensions**
- 4. Distance from rear edge of deck to rear property line**
- 5. Length of rear yard**
- 6. Width of property**
- 7. Floor plan with dimensions**
- 8. Elevation**
- 9. Height off ground**
- 10. Style and height of railing**

Standard Townhouse Deck/Patio Application Checklist

Please read both sides of the attached application form and complete the specified portion on the front side. **INCOMPLETE APPLICATIONS WILL BE RETURNED**

Your Deck or Patio application **MUST** contain the following items and information. Please check off each item as you address it in your application. A sample deck application is shown in Appendix C of the Community Guidelines Handbook.

Please indicate the following on a copy of your *legal site plat*. (The site plat or property plat should have been provided with your settlement documents.)

_____ location of deck or patio drawn to scale

_____ exact dimensions of deck or patio

_____ distances from deck or patio to both side property lines. (This shall be no less than one foot (1') for an upper-level deck. Ground level decks and patios may extend to the side property lines.)

_____ distance from rear property line

length of back yard (from back of house to rear property line)

Please indicate the following on separate drawings:

_____ floor plan, with dimensions, of deck or patio (top view)

_____ specify location of benches (if any) on floor plan

_____ front elevation showing deck against house

_____ height of decking off ground

style and height of railing (Height must be 36" and style must be vertical picket with spacing between pickets being 6" on center.)

dimensions and elevation (side view) of steps

Please indicate here:

- Type of wood _____ (Fencing material must be pressure treated pine or a naturally weather-resistant wood) (Decks material may be pressure treated pine or a naturally weather-resistant wood or composite i.e., Trex, TimberTech)
- State that the wood will be left to weather naturally _____
- Specify if lattice will be used: _____ (Please note that lattice on ground-level Decks may not exceed the height of the deck floor.) Proposed Lattice on upper-level Decks must be submitted for formal review by the NAC and DRC Committees.
- If benches will be used, specify height. (Bench height may not exceed one-half (1/2) of the height of the railing, if any, or eighteen inches (18").

For Patios only:

- Indicate type of material _____ (brick, stone, or concrete).
- Indicate whether landscape timbers will be used _____ (must be flush with the patio)

Sample Site Plat

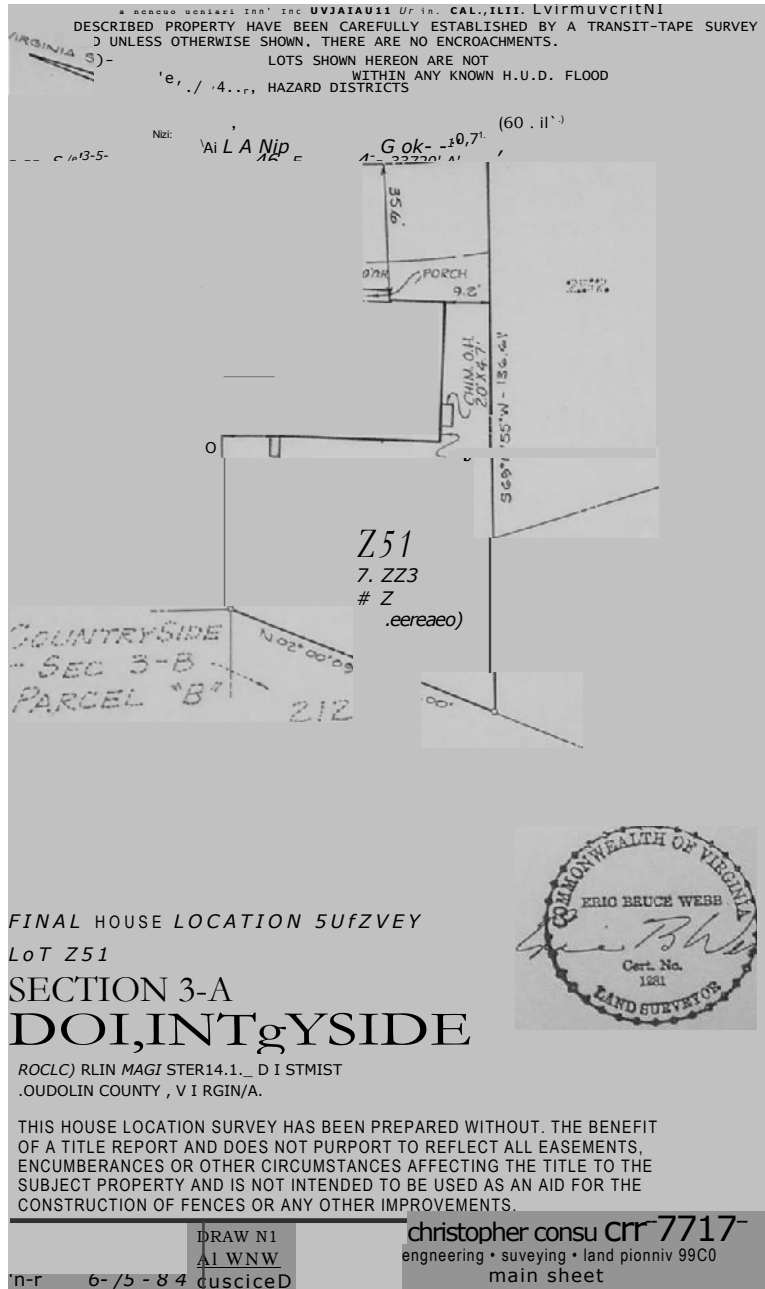

Sample 3 - Attic Ventilator

1. description indicates color
2. signatures of the four neighbors to whom the ventilator will be most visible
3. site plat with location of ventilator marked
4. it is helpful to include a picture of the actual product to be installed
5. dimensions of ventilator must be noted
6. elevation showing placement below roof line

Sample 4- Fence

1. Fence applications must include a completed Fence Application Checklist.
2. General description (specifics are on Fence Application Checklist).
3. Most important are the signatures of four neighbors whose properties border yours. If there are fewer than four homes on property bordering yours, include neighbors whose property faces yours.
4. Location of proposed fence on site plat includes location and style of existing fencing on bordering properties. Exact location of gates must also be shown here.
5. Drawing shows style of fence and gate(s).

Fence Application Checklist

Please read both sides of the attached application form and complete the specified portion of the front side.

INCOMPLETE APPLICATIONS WILL BE RETURNED.

Your fence application **MUST** contain the following items and information. Please check off each item as you address it in your application. A sample fence application is shown in Appendix C of the Community Guidelines Handbook.

1. Please indicate the following on a copy of your legal site plat. (The site plat should be located with your settlement documents.)

_____ exact location of fence

_____ exact placement of all gates

_____ style of fencing on adjacent lots

2. Attach a drawing of a segment of the proposed fence and gate(s) indicating the following.

_____ style of fence by name (e.g., Gothic picket, 6 board estate, etc.)

_____ style of gates by name (e.g., convex flat board, split rail, etc.)

_____ height of fence

_____ dimensions of gate(s)

_____ width of boards

_____ spacing between boards (if picket)

3. Please indicate the following here.

A. Type of wood _____

B. Color of wood (if fence is to be stained or painted, **please include 8 color samples and the color of the house and trim must be specified.**)

_____ natural

_____ stain (name of color) _____

_____ paint (name of color) _____

color of house _____

color of trim _____

C. Will wire mesh be used? _____ Yes _____ No

If "yes," specify color dark green brown

Please note that wire mesh shall be vinyl-coated; 2 by 3 inch rectilinear; attached to the inside of the fence; and not extend above the top rail.

D. Number of gates _____

E. Fence will be within 1" of the property line. _____ Yes _____ No

If “no”, please explain why.

- F. Will fence extend forward of the sight lines? _____ Yes _____ No

If “yes,” please explain why. (Refer to the Community Guidelines Handbook section on “Fences” for a definition of sight line” and discussion of possible exceptions.)

- F. My Contract specifies the FENCE will be within 1” of the property line. This requirement should be in your agreement with the contractor to avoid disagreement or conflict with your neighbor or contractor.

Should the location of the fence become an issue, a survey to verify where the fence is located will be required and is the responsibility of the owner of the property that contracted to install the fence.

. Yes _____ No _____

- G. Will gates open into adjacent properties? _____ Yes, _____ No

If “yes,” please explain why.

Please see the Community Guidelines Handbook sections on FENCES and “Appendix C -Sample Applications” for more information.

Appendix D – Illustrations

Standard Townhouse Deck

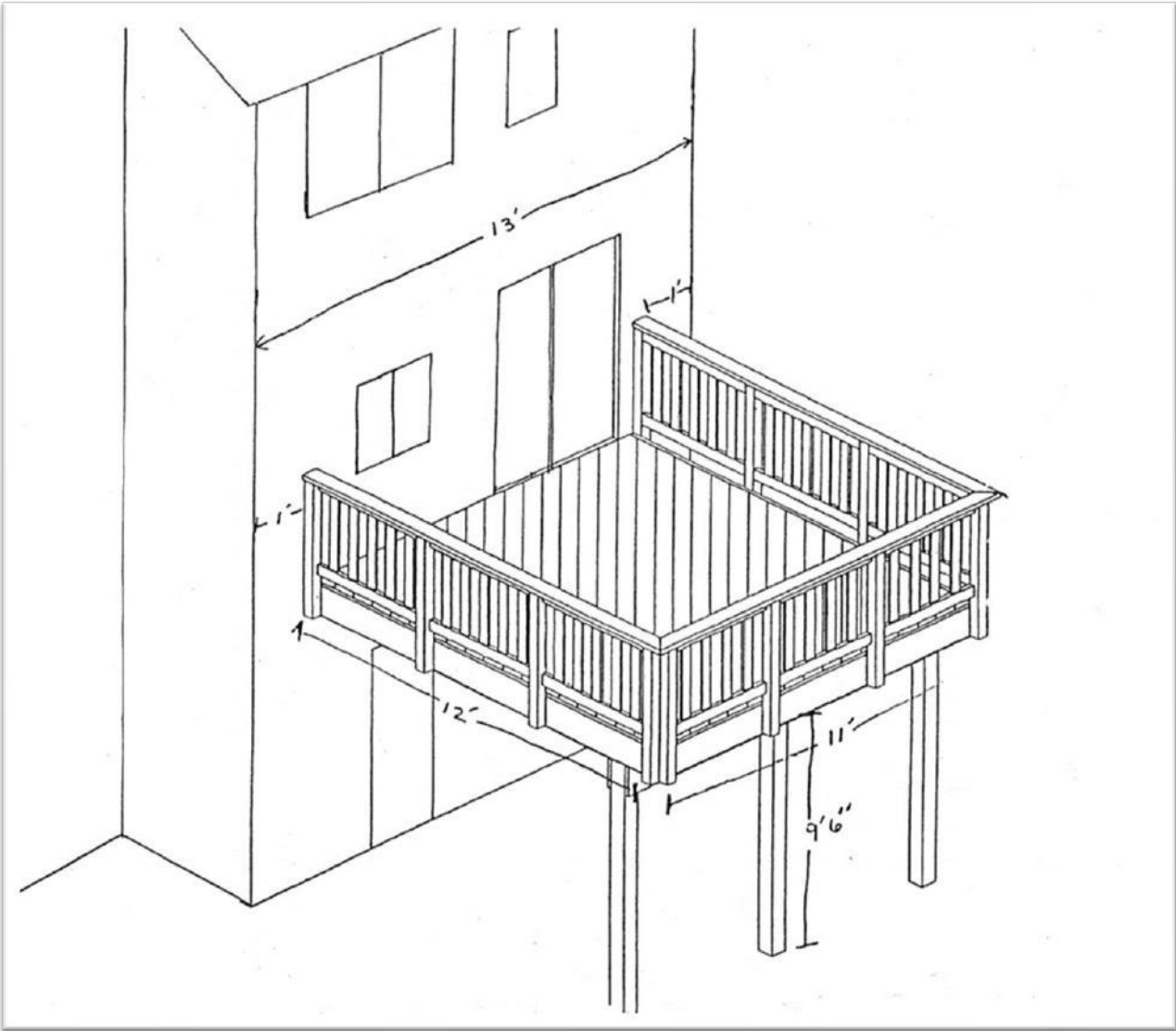

Fence Styles (single family and manor homes)

4.0' WOODEN FENCE

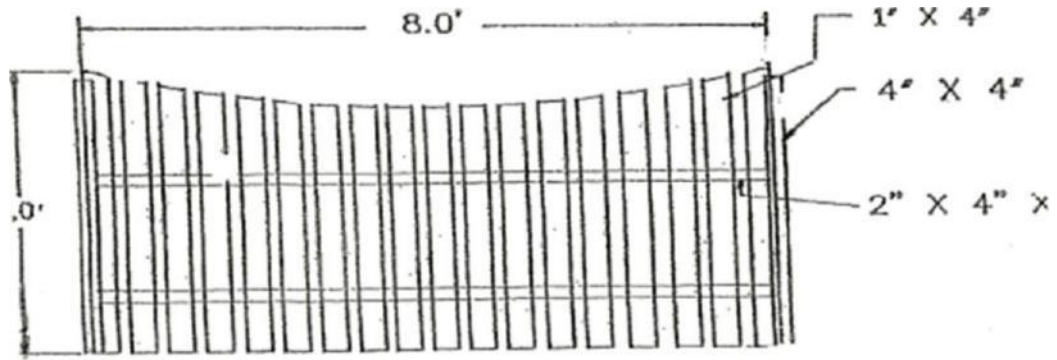

STYLE. MT. VEJ1NON PICKET

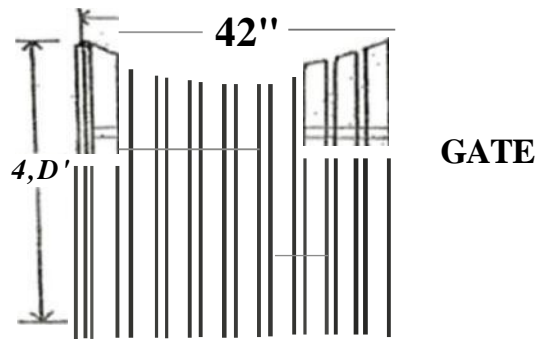

Arched Picket Fence style (single family and manor home)



Spaced Picket (single family and manor home)

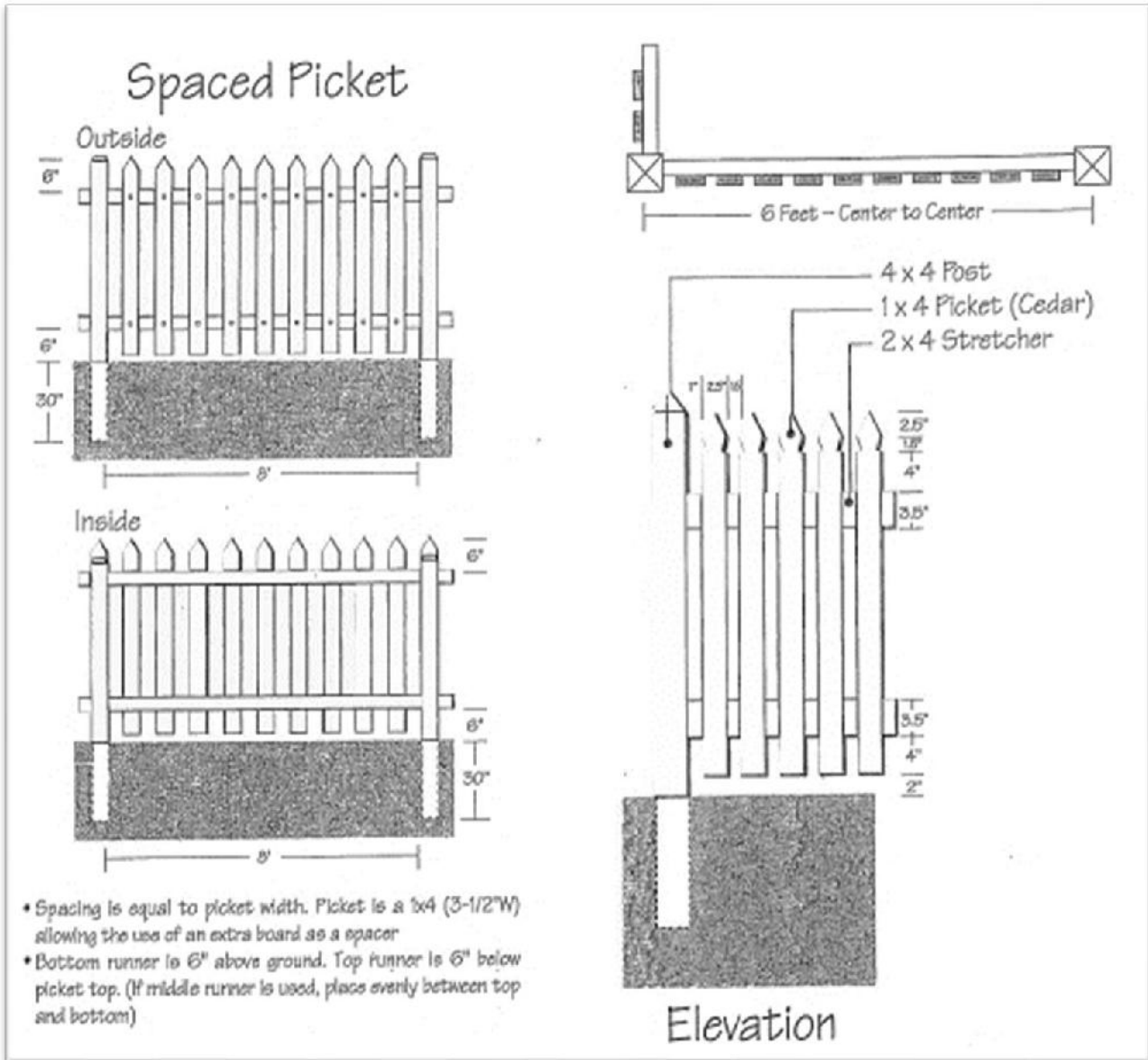

Estate and Split Rail Fence (single family and manor home)

Estate

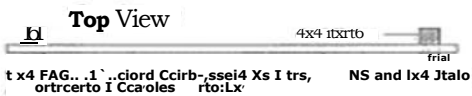
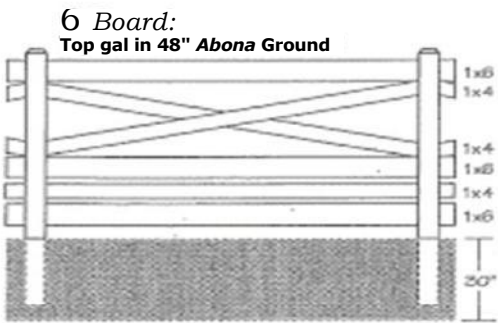
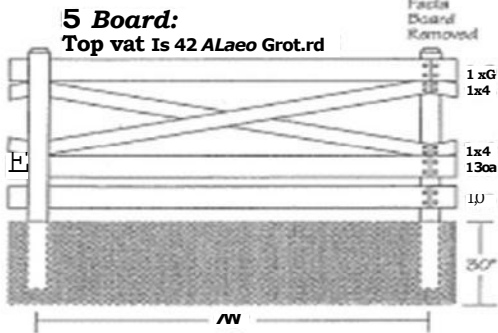

Split Rail

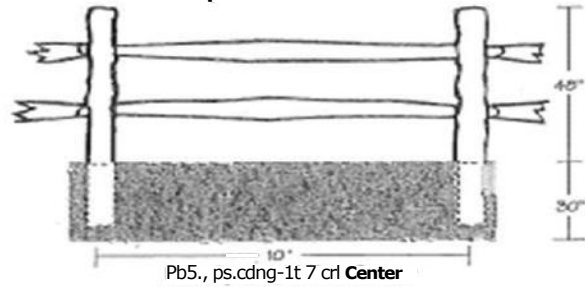

- Generally, wood posts how a lot aide an 4 a rounded end; all posts should face the same direction. The rails of each section overlap each other, lock'ne the rails should all lap each other in a uniform manner. I.e. either all outside or all inside.
- Post spacing to 10' on center; rails are 11' long spaced at 10' intervals. The rails of each section overlap each other, lock'ne the rails should all lap each other in a uniform manner. I.e. either all outside or all inside.
- If short sections are required, the short section should be placed in the least visible area. I.e. the rear corner.

Flat Cap Picket Style Fence (Oatlands Single Family Homes)



Standard Townhouse Fence

“Standard” townhouse fencing is “Board on Board” or “shadowbox” style. Pressure treated wood with no color change.

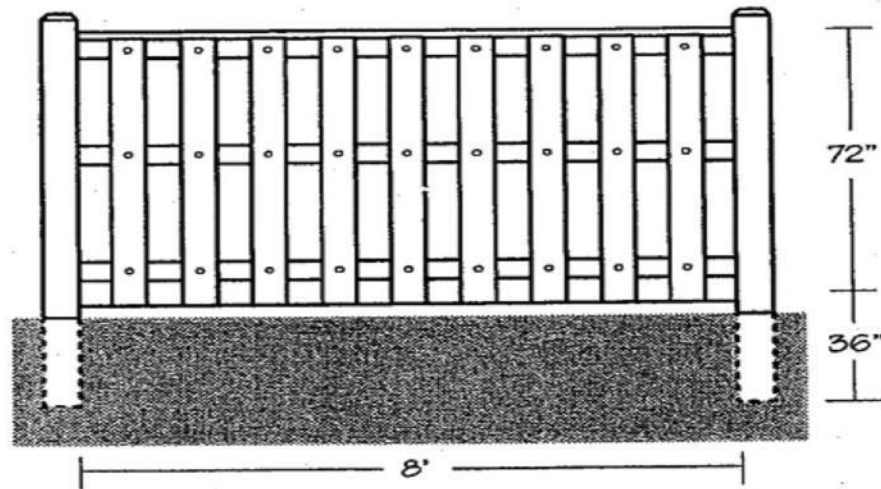

Top View (Capboard Removed)

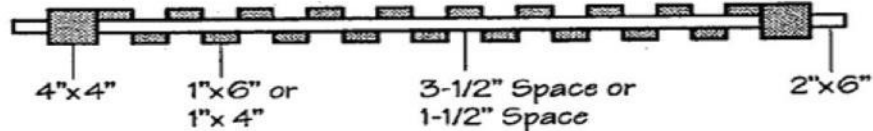

NOTES:

- Vertical boards alternate on either side so as to give same appearance to both sides
- Runners are toe nailed to center of posts.
- Fences 6' high have 3 runners.

Material

Posts: 4 x 4 Pressure treated pine or equal

Runners: 2 x 4 x 8 Kiln dried Hem/Fir

Vertical Boards: 1 x 4 Pressure treated pine or equal for Scarborough townhouses
1 x 6 Pressure treated pine or equal for Globe townhouses

Capboard: 1 x 4 x 8 Pressure treated pine or equal

GATES

Convex

YOBS: • it Y sync that este pers re on pin
 • Wrerewer OW*. ndd Nen 4 an a WO pest (is.
 On ASS Ir away Men .to, se Wes en War Sr
 cof Ow OM to pr044 SSW name Wow)

Step rlvacy Pellets 50 They
 Accomodate Undulating topography
 Use harems at 2 Feet 4 6.6 srd to Pea.
 Try to Repeat 2 or 5 Lentals ThrOulreirt Any ^{CP/teelfg'''''}
 • tenso.

of at Wan pistcy esece• tan
 fceosten, cceteur tithe Unit



TOWNHOUSE FENCING

INCORRECT FENCE STYLE



CORRECT STYLE- FENCING



CORRECT STYLE- GATE



Roof Slope Comparison

